



NEHRP Seismic Design Technical Brief No. 6



Seismic Design of Cast-in-Place Concrete Special Structural Walls and Coupling Beams

A Guide for Practicing Engineers

Jack P. Moehle
Tony Ghodsi
John D. Hooper
David C. Fields
Rajnikanth Gedhada

NEHRP Seismic Design Technical Briefs

The National Earthquake Hazards Reduction Program (NEHRP) Technical Briefs are published by the National Institute of Standards and Technology (NIST), as aids to the efficient transfer of NEHRP and other research into practice, thereby helping to reduce the nation's losses from earthquakes.

NIST National Institute of Standards and Technology

The National Institute of Standards and Technology (NIST) is a federal technology agency within the U.S. Department of Commerce that promotes U.S. innovation and industrial competitiveness by advancing measurement science, standards, and technology in ways that enhance economic security and improve our quality of life. It is the lead agency of the National Earthquake Hazards Reduction Program (NEHRP). Dr. John (Jack) R. Hayes, Jr. is the Director of NEHRP, within NIST's Engineering Laboratory (EL). Dr. Jeffery J. Dragovich managed the project to produce this Technical Brief for EL.

NEHRP Consultants Joint Venture

This NIST-funded publication is one of the products of the work of the NEHRP Consultants Joint Venture carried out under Contract SB134107CQ0019, Task Order 10254. The partners in the NEHRP Consultants Joint Venture are the Applied Technology Council (ATC) and the Consortium of Universities for Research in Earthquake Engineering (CUREE). The members of the Joint Venture Management Committee are James R. Harris, Robert Reitherman, Christopher Rojahn, and Andrew Whittaker, and the Program Manager is Jon A. Heintz.

About The Authors

Jack P. Moehle, Ph.D., P.E., is T.Y. and Margaret Lin Professor of Engineering at the University of California, Berkeley, where he teaches and conducts research on earthquake-resistant concrete construction. He is a Fellow of the American Concrete Institute, and has served on the ACI Code Committee 318 since 1989 and as chair of the seismic subcommittee since 1995. He is a Fellow of the Structural Engineers Association of California and Honorary Member of the Structural Engineers Association of Northern California.

Tony Ghodsi, P.E., S.E., is a Principal at Englekirk Structural Engineers, a structural engineering firm headquartered in Los Angeles, California. He is a member of the Los Angeles Tall Buildings Structural Design Council and on the Board of Advisors at the University of Southern California Department of Civil and Environmental Engineering.

John D. Hooper, P.E., S.E., is Director of Earthquake Engineering at Magnusson Klemencic Associates, a structural and civil engineering firm headquartered in Seattle, Washington. He is a member of the Building Seismic Safety Council's 2014 Provisions Update Committee and chair of the American Society of Civil Engineers Seismic Subcommittee for ASCE 7-10.

David C. Fields, P.E., S.E., is a Senior Project Manager at Magnusson Klemencic Associates, a structural and civil engineering firm headquartered in Seattle, Washington. He is a member of American Concrete Institute Committee 374: Performance Based Design of Concrete Buildings and the Structural Engineers Association of Washington Earthquake Engineering Committee.

Rajnikanth Gedhada, P.E., S.E., is a Project Structural Engineer at Englekirk Structural Engineers, a structural engineering firm headquartered in Los Angeles, California. He is a member of the Structural Engineers Association of Southern California.

About the Review Panel

The contributions of the three review panelists for this publication are gratefully acknowledged.

D. E. Lehman, Ph.D., is the John R. Kiely Associate Professor of Civil and Environmental Engineering at the University of Washington. She conducts research on seismic response of engineered structures with an emphasis on the use of large-scale experimental methods. She is also the Director of the Structural Research Laboratory at the University of Washington.

John W. Wallace, Ph.D., P.E., is Professor of Structural/Earthquake Engineering at the University of California, Los Angeles, where he teaches and conducts research on earthquake-resistant concrete construction. He is a Fellow of the American Concrete Institute and has served on the ACI 318 seismic subcommittee since 1995. He also has served as a member of the American Society of Civil Engineers Seismic Subcommittee for ASCE 7-05 and the ASCE 41-06 Supplement #1 concrete provisions update committee. He is a member of the Los Angeles Tall Buildings Structural Design Council.

Loring A. Wyllie, Jr. is a Structural Engineer and Senior Principal of Degenkolb Engineers in San Francisco, California. He is the 2007 recipient of the American Society of Civil Engineers Outstanding Projects and Leaders (OPAL) design award. He is a past president of the Structural Engineers Association of California and the Earthquake Engineering Research Institute. He is a member of the Structural Concrete Building Code Committee 318 of the American Concrete Institute and an Honorary Member of ACI.



Applied Technology Council (ATC)
201 Redwood Shores Parkway - Suite 240
Redwood City, California 94065
(650) 595-1542
www.atccouncil.org email: atc@atccouncil.org



Consortium of Universities for Research in
Earthquake Engineering (CUREE)
1301 South 46th Street - Building 420
Richmond, CA 94804
(510) 665-3529
www.curee.org email: curee@curee.org

Seismic Design of Cast-in-Place Concrete Special Structural Walls and Coupling Beams

A Guide for Practicing Engineers

Prepared for
*U.S. Department of Commerce
Engineering Laboratory
National Institute of Standards and Technology
Gaithersburg, MD 20899-8600*

By

Jack P. Moehle, Ph.D., P.E.
University of California, Berkeley

Tony Ghodsi, P.E., S.E.
Englekirk Structural Engineers

John D. Hooper, P.E., S.E.
Magnusson Klemencic Associates

David C. Fields, P.E., S.E.
Magnusson Klemencic Associates

Rajnikanth Gedhada, P.E., S.E.
Englekirk Structural Engineers

August 2011
Revised March 2012



U.S. Department of Commerce
John Bryson, Secretary

National Institute of Standards and Technology
*Patrick D. Gallagher, Under Secretary of Commerce for
Standards and Technology and Director*

Contents

1. Introduction.....	1
2. The Use of Special Structural Walls.....	2
3. Principles for Special Structural Wall Design.....	7
4. Building Analysis Guidance.....	11
5. Design Guidance.....	13
6. Additional Requirements.....	27
7. Detailing & Constructability Issues.....	30
8. References.....	33
9. Notation and Abbreviations.....	34
10. Credits.....	37

Errata to GCR 11-917-11

Updated: March 2012

The following errors were contained in the August 2011 Edition of Technical Brief No. 6.

The error was in the last paragraph of Section 5.1, where it said: “For coupling beams, $\phi = 0.85$ for shear and 0.9 for flexure.” The correction in this version says: “For diagonally reinforced coupling beams, $\phi = 0.85$ for shear. For conventionally reinforced coupling beams, $\phi = 0.75$ for shear and 0.9 for flexure.”

In the paragraph following Figure 5-1 on page 14, “ $c = 0.1l_w$ ” should be “ $c = 0.1l_w$ ”. Also the first full paragraph in the second column on page 20 includes the term $(480 + 0.8f'_c)A_{cv}$. It should be $(480 + 0.08f'_c)A_{cv}$.

On page 22, the bold text following bullet b. should read “Coupling beams with $l_w/h < 2$ and $V_u > 4\lambda\sqrt{f'_c}A_{cw}$ ”
The term A_{cw} was missing.

Disclaimers

This Technical Brief was prepared for the Engineering Laboratory of the National Institute of Standards and Technology (NIST) under the National Earthquake Hazards Reduction Program (NEHRP) Earthquake Structural and Engineering Research Contract SB134107CQ0019, Task Order 10254. The statements and conclusions contained herein are those of the authors and do not necessarily reflect the views and policies of NIST or the U.S. Government.

This report was produced by the NEHRP Consultants Joint Venture, a partnership of the Applied Technology Council (ATC) and the Consortium of Universities for Research in Earthquake Engineering (CUREE). While endeavoring to provide practical and accurate information, the NEHRP Consultants Joint Venture, the authors, and the reviewers assume no liability for, nor express or imply any warranty with regard to, the information contained herein. Users of the information contained in this report assume all liability arising from such use.

The policy of NIST is to use the International System of Units (metric units) in all of its publications. However, in North America in the construction and building materials industry, certain non-SI units are so widely used instead of SI units that it is more practical and less confusing to include measurement values for customary units only in this publication.

Cover photo – Reinforcing of special reinforced concrete walls, Engineering 5 Building, UCLA.

How to Cite this Publication

Moehle, Jack P., Ghodsi, Tony, Hooper, John D., Fields, David C., and Gedhada, Rajnikanth (2011). “Seismic design of cast-in-place concrete special structural walls and coupling beams: A guide for practicing engineers,” *NEHRP Seismic Design Technical Brief No. 6*, produced by the NEHRP Consultants Joint Venture, a partnership of the Applied Technology Council and the Consortium of Universities for Research in Earthquake Engineering, for the National Institute of Standards and Technology, Gaithersburg, MD, NIST GCR 11-917-11REV-1.

1. Introduction

The basic structural elements of an earthquake-resistant building are diaphragms, vertical framing elements, and the foundation. In reinforced concrete buildings, the vertical elements are usually either moment-resisting frames or structural walls (sometimes referred to as shear walls). Special reinforced concrete structural walls are walls that have been proportioned and detailed to meet special code requirements for resisting combinations of shear, moment, and axial force that result as a building sways through multiple displacement cycles during strong earthquake ground shaking. Special proportioning and detailing requirements result in a wall capable of resisting strong earthquake shaking without unacceptable loss of stiffness or strength.

Although special structural walls can be used in any building, the *International Building Code* (IBC 2009) only requires them wherever cast-in-place or precast walls are used to resist seismic forces in new buildings assigned to Seismic Design Category D, E, or F. The design force levels are specified in *Minimum Design Loads for Buildings and Other Structures (ASCE/SEI 7-10)* (ASCE 2010), and the design proportions and details are defined in the *Building Code Requirements for Structural Concrete (ACI 318-11)* and *Commentary (ACI 2011)*. This Guide uses units of measure consistent with these codes and standards, (e.g., inches, pounds, pounds per square inch).

The design requirements for special structural walls are governed by numerous interrelated requirements in these three building codes or standards, making their application challenging for even the most experienced designers. This Guide first describes the use of structural walls, then clarifies intended behavior, and finally lays out the design steps and details so that design and construction can be accomplished efficiently. The Guide is intended especially for the practicing structural engineer, though it will also be useful for building officials, educators, and students.

This Guide emphasizes the most common types of special reinforced concrete structural walls, which use cast-in-place, normalweight aggregate concrete and deformed, non-prestressed reinforcement. Wall configurations vary depending on the application, and may include coupling beams. Building codes permit the use of special walls using precast concrete, lightweight aggregate concrete, or prestressed reinforcement. Building codes also permit the use of ordinary cast-in-place structural walls in buildings assigned to Seismic Design Category A, B, or C, and intermediate precast walls in some buildings assigned to Seismic Design Category A, B, C, D, E, or F. The interested reader is referred to ACI 318 for specific requirements for these other systems, which are outside the scope of this Guide.

This Guide emphasizes code requirements and accepted approaches to their implementation. It also identifies good practices that go beyond the code minimum requirements. Background information and illustrative sketches clarify the requirements and recommendations.

Sections 2 and 3 describe the use of structural walls in buildings and discuss intended behavior. Section 4 provides analysis guidance. Section 5 presents the design and detailing requirements of ACI 318 along with guidance on how to apply them. Section 6 presents additional requirements for wall buildings assigned to Seismic Design Category D, E, or F, and Section 7 presents detailing and constructability challenges for special structural walls with illustrative construction examples.

Codes Referenced in this Guide

U.S. building codes are continually undergoing revisions to introduce improvements in design and construction practices. At the time of this writing, the building code editions most commonly adopted by state and local jurisdictions include the 2009 edition of the IBC, the 2005 edition of ASCE 7, and the 2008 edition of ACI 318. This Guide is written, however, according to the latest editions of each of these documents, that is, IBC (2009), ASCE 7 (2010), and ACI 318 (2011). In general, the latest editions of these three documents are well coordinated regarding terminology, system definition, application limitations, and overall approach. The most significant changes relative to the previous editions include:

- ASCE 7 (2010) introduces Risk-targeted Maximum Considered Earthquake (MCE_R) ground motions and replaces “occupancy categories” with “risk categories.”
- ACI 318 (2011) introduces provisions for wall piers and modifies requirements for anchorage of wall horizontal reinforcement in wall boundaries.

Hereafter, this Guide uses IBC to refer to IBC 2009, ASCE 7 to refer to ASCE 7 2010, and ACI 318 to refer to ACI 318-2011.

Sidebars in the Guide

Sidebars are used in this Guide to illustrate key points and to provide additional guidance on good practices and open issues in analysis, design, and construction.

2. The Use of Special Structural Walls

2.1 Structural Walls in Buildings

Walls proportioned to resist combinations of shears, moments, and axial forces are referred to as structural walls. A special structural wall is one satisfying the requirements of ACI 318, Chapter 21, intended to result in strength and toughness required to resist earthquake effects in buildings assigned to Seismic Design Categories D, E, or F. In buildings, they are used in many different configurations; some are illustrated in **Figure 2-1**. Solid walls are widely used to brace low-rise buildings. Sometimes walls are perforated with openings. In taller buildings, walls cantilever from a foundation to provide bracing over the building height. Isolated walls can be connected using coupling beams extending between window and door openings, creating a coupled wall system that is stiffer and stronger than the isolated pair of walls.

Structural Walls and Shear Walls

ACI 318 refers to structural walls and, with regard to Seismic Design Categories D through F, special structural walls. The equivalent terms used by ASCE 7 are shear walls and special shear walls.

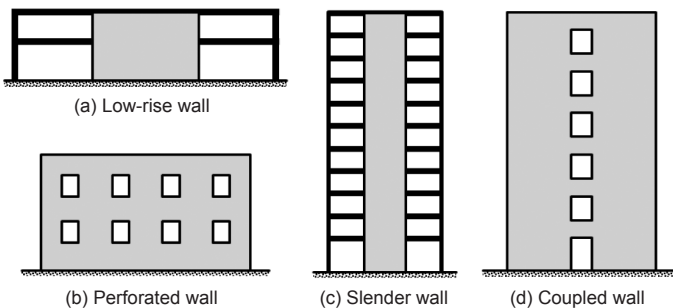

Figure 2-1 – Some illustrative structural wall elevations.

2.2 When to Use Structural Walls

Selection of special structural walls as primary seismic force-resisting elements is influenced by considerations of seismic performance, functionality, constructability, and cost. For low-to mid-rise buildings, structural walls typically are more cost-effective than other systems such as concrete special moment frames. Structural walls are used in concrete buildings with limited floor-to-floor heights or other architectural constraints that cannot accommodate frame beam depths. Stairway and elevator cores are natural locations for structural walls, which serve a dual purpose of enclosing vertical shafts while providing efficient axial and lateral resistance.

ASCE 7 imposes height limits for buildings in which special structural walls compose the seismic force-resisting system, specifically 160 ft in Seismic Design Category D and E and 100 ft in Seismic Design Category F. These heights can be increased to 240 ft and 160 ft, respectively, if the building does not have an extreme torsional irregularity and the shear in any line of walls does not exceed 60 % of the total story shear (ASCE 7 § 12.2.5.4). There is no height limit for a dual system combining walls with special moment frames capable of resisting at least 25 % of prescribed seismic forces.

2.3 Wall Layout

Structural walls are generally stiff structural elements whose placement in a building can strongly affect building performance. Walls should be proportioned and located considering the range of loads the building will experience during its service life. The engineer and architect should work together to arrive at a building configuration in which walls are located to meet structural, architectural, and programmatic requirements of the project.

2.3.1 Plan Layout

Walls should be well distributed within the building plan, with multiple walls providing resistance to story shears in each principal direction. Preferably, long diaphragm spans are avoided. Furthermore, the walls should be positioned such that their center of resistance is close to the center of mass, thereby avoiding induced torsion (**Figure 2-2**). Walls located near the perimeter may be preferred because they maximize torsional resistance.

Tributary gravity loads help resist wall overturning moments, reducing reinforcement and foundation uplift demands. Therefore, it may be desirable to move walls inward from the perimeter and away from adjacent columns so that they support

Building Torsion

ASCE 7 contains provisions that quantify torsional irregularity, including penalties for large irregularities. The code requirements refer only to linear-elastic response. If a building is expected to respond inelastically, the center of resistance ideally should coincide with center of mass for both linear response and for response at strength level. Where identical walls are symmetrically placed (e.g., walls a and b in **Figure 2-2a**), this objective is relatively easy to achieve. Additional design effort is required where walls are asymmetrically arranged.

more gravity loads, as in Wall **e** in **Figure 2-2a**, even though this reduces plan torsion resistance. Too much axial force can result in undesirable compression-controlled flexural response. A good plan layout balances these competing objectives.

In buildings with post-tensioned slabs, stiff in-line walls can act to resist slab elastic and creep shortening, sometimes with deleterious effect. Walls **c** and **d** (**Figure 2-2**) would resist slab shortening along line **cd**, such that post-tensioning force would tend to transfer from the slab and into the walls. Walls **a**, **b**, and **e** are well positioned to allow slab shortening.

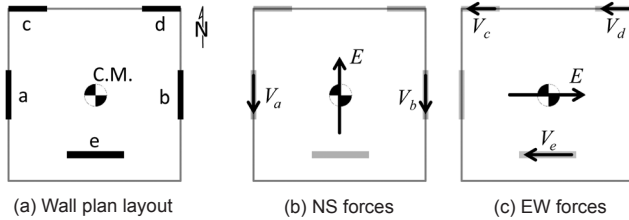

Figure 2-2 – Example plan layout. C.M. refers to center of mass.

2.3.2 Vertical Discontinuities

Considerations of function and cost sometimes lead to wall openings and other wall discontinuities. Under lateral loading, these irregularities can lead to stress concentrations and localized lateral drift that may be difficult to quantify and accommodate in design, and in some cases may result in undesirable seismic response. Some irregularities should be avoided without further consideration; other cases will require additional analysis and design effort.

In the past, demand for open space in the first story led to many older buildings in which walls from upper stories were discontinued in the first story, creating a weak first story (**Figure 2-3a**). These have performed poorly in past earthquakes (**Figure 2-4**). This configuration, classified by ASCE 7 as an Extreme Weak Story Irregularity, is no longer permitted in new buildings assigned to Seismic Design Categories D, E, or F.

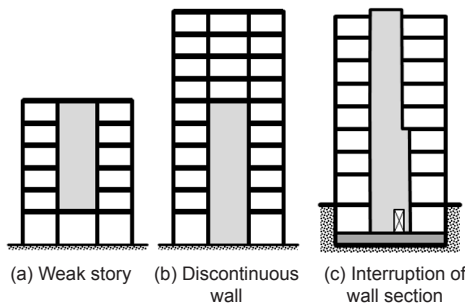

Figure 2-3 – Wall vertical irregularities.



Figure 2-4 – Weak story damage, 1971 San Fernando earthquake.

Walls extending from the foundation and discontinued at some intermediate level (**Figure 2-3b**) are permitted by ASCE 7, but the design is penalized by increased seismic design forces. It is preferred to have more gradual reduction in wall section (either length, thickness, or both), as illustrated by **Figure 2-3c**.

Openings in walls disrupt the flow of forces and are best located in regular patterns that produce predictable force transfers. **Figures 2-1b** and **d** show examples of regularly located wall openings. For such buildings, good design practice keeps vertical wall segments (piers) stronger than beams so that story failure mechanisms are avoided. Sometimes programmatic demands require openings in a less regular pattern (**Figure 2-3c**). These should be avoided where feasible. Where unavoidable, they require additional design and detailing effort to develop force transfers around openings. See Section 5.9.

2.3.3 Diaphragm Connectivity

In a building braced by structural walls, inertial forces generated by building vibration are transmitted through diaphragms to the walls, which in turn transmit the forces to the foundation. Good connections between diaphragms and structural walls are essential to the seismic force path. This subject is discussed in depth by Moehle et al. (2010).

Programmatic requirements often locate diaphragm openings adjacent to structural walls, complicating the seismic force path. This can be especially acute at podium slabs where large wall forces may be transferred through the diaphragm to other stiff elements (**Figure 2-5a**). Good diaphragm transfer capacity is facilitated by solid diaphragms surrounding walls, rather than significantly perforated diaphragms (**Figure 2-5b**).

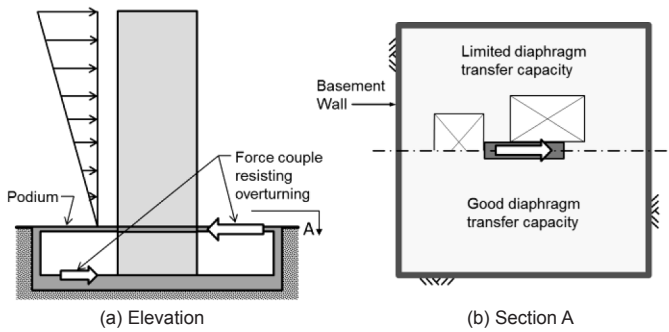

Figure 2-5 – Force transfers between walls and diaphragms.

2.4 Wall Foundations

In low-rise buildings with long walls supporting sufficient gravity loads, spread footings may be adequate to resist design overturning moments. For higher overturning demands, pile foundations, possibly including tension tie-down capacity, can be used. More commonly, foundation elements are extended to pick up additional gravity loads. **Figure 2-6a** shows a grade beam acting as a foundation outrigger. Basement walls also can be proportioned to act as outrigger elements (**Figure 2-6b**). Alternatively, a wall extending into subterranean levels can use a horizontal force couple formed between the grade-level diaphragm and diaphragms below to transfer the overturning moment to adjacent basement walls (**Figure 2-6c**).

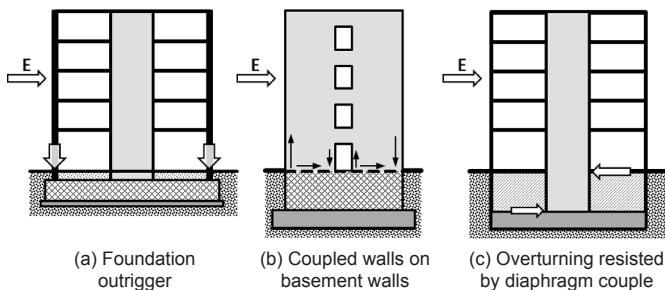

Figure 2-6 – Various ways to spread overturning resistance.

If none of these solutions work, foundation rocking may need to be accepted. U.S. building codes do not recognize uplifting walls as an accepted seismic force-resisting system; either special approval is required or the wall cannot be counted on to provide seismic force resistance. Regardless, uplifting walls can impose large deformation demands on adjacent framing members that should be accommodated through design.

2.5 Wall Configurations

Special structural walls can be configured in numerous ways (**Figure 2-7**). Rectangular cross sections are relatively easy to design and construct; very thin sections can have performance problems and should be avoided. “Bar bell” walls have

boundary columns that contain longitudinal reinforcement for moment resistance, improve wall stability, and create an element to anchor beams framing into the wall. The boundary columns, however, might create an architectural impediment and increase forming costs. Intersecting wall segments can be combined to create flanged walls, including T, L, C, and I configurations. Core walls enclose elevators, stairways, and other vertically extruded areas, with coupling beams connecting wall components over doorways. In these walls, any wall segment aligned parallel to the lateral shear force acts as a web element resisting shear, axial force, and flexure, while orthogonal wall segments act as tension or compression flanges.

Walls with openings are considered to be composed of vertical and horizontal wall segments (**Figure 2-8**). A vertical wall segment is bounded horizontally by two openings or by an opening and an edge. Similarly, a horizontal wall segment is bounded vertically by two openings or by an opening and an edge. Some walls, including some tilt-up walls, have narrow vertical wall segments that are essentially columns, but whose dimensions do not satisfy requirements of special moment frame columns. In consideration of these, ACI 318 defines a wall pier as a vertical wall segment having $l_w/b_w \leq 6.0$ and $h_w/l_w \geq 2.0$. The lower left vertical wall segment in **Figure 2-8b** might qualify as a wall pier. Special provisions apply to wall piers (Section 5.7).

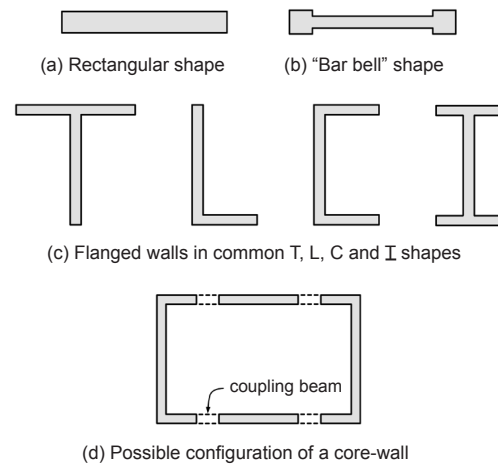

Figure 2-7 – Various wall cross sections.

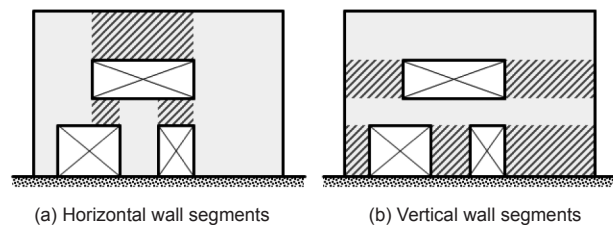

Figure 2-8 – Vertical and horizontal wall segments (hatched).

The term coupled wall refers to a system in which cantilever walls are connected by coupling beams aligned vertically over wall height (Figure 2-9). The design goal is to develop a ductile yielding mechanism in the coupling beams over the height of the wall followed by flexural yielding at the base of the individual cantilever walls. Depending on geometry and design forces, a coupling beam can be detailed as either a conventionally reinforced beam or diagonally reinforced beam. See Section 5.8.

In taller buildings, outriggers can be used to engage adjacent columns, thereby increasing building stiffness and reducing upper-story drifts. Outriggers can be incorporated conveniently in floors housing mechanical equipment or at the roof level.

2.6 Wall Reinforcement

Figure 2-10 illustrates typical reinforcement for a special structural wall of rectangular cross section. As a minimum, a special structural wall must have distributed web reinforcement in both horizontal and vertical directions. In many cases, a special structural wall also will have vertical reinforcement concentrated at the wall boundaries to provide additional resistance to moment and axial force. Typically, longitudinal reinforcement is enclosed in transverse reinforcement to confine the concrete and restrain longitudinal bar buckling.

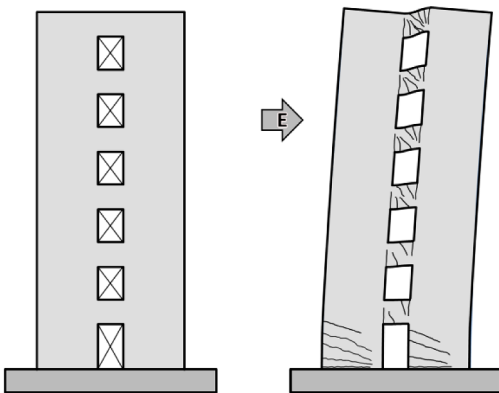

Figure 2-9 – Coupled wall geometry and target yield mechanism.

The distributed web reinforcement ratios, ρ_v for vertical reinforcement and ρ_h for horizontal reinforcement, must be at least 0.0025, except that ρ_h and ρ_v are permitted to be reduced if $V_u \leq A_{cv}\lambda\sqrt{f'_c}$. Reinforcement spacing each way is not to exceed 18 inches. At least two curtains (layers) of reinforcement are required if $V_u > 2A_{cv}\lambda\sqrt{f'_c}$. Reinforcement ρ_h also is to be designed for wall shear forces, as described in Section 5.4. Finally, if $h_w/l_w \leq 2.0$, ρ_h is not to be less than the provided ρ_v . ACI 318 has no requirements about whether vertical or horizontal distributed reinforcement should be in the outer layer, although lap splices of vertical reinforcement will perform better if horizontal bars are placed outside the vertical bars as shown in Figure 2-10.

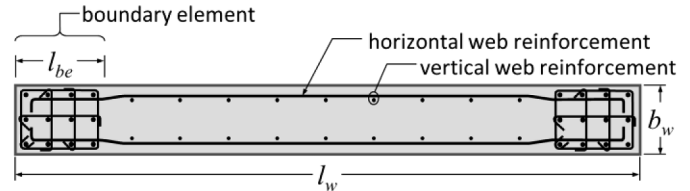

Figure 2-10 – Typical reinforcement for rectangular wall.

A boundary element is a portion along a structural wall edge or opening that is strengthened by longitudinal and transverse reinforcement. Where combined seismic and gravity loading results in high compressive demands on the edge, ACI 318 requires a special boundary element. These have closely spaced transverse reinforcement enclosing the vertical boundary bars to increase compressive strain capacity of core concrete and to restrain longitudinal bar buckling. See Section 5.3.3.

2.7 Wall Proportioning

Walls should be proportioned to satisfy strength and drift limit requirements of ASCE 7, unless an alternative approach is approved. According to ASCE 7, walls are designed for load combinations in which seismic forces, E , are determined using a force reduction factor, R . The value of R depends on whether the wall is part of a Dual System ($R = 7$), a Building Frame System ($R = 6$), or a Bearing Wall System ($R = 5$). To qualify as a Dual System, the special structural walls must be combined with special moment frames capable of resisting at least 25 % of prescribed seismic forces. If it does not qualify as a Dual System, then it can qualify as a Building Frame System if it has an essentially complete space frame providing support for vertical loads, with structural walls providing seismic force-resistance. If there is not a complete space frame providing support for vertical loads, the system must be designed as a Bearing Wall System.

Building Frame System versus Bearing Wall System

Different jurisdictions interpret the ASCE 7 provisions differently. San Francisco (DBI, 2009) declares the wall to be a bearing wall if it supports more than 5 % of the entire building floor and roof loads in addition to self-weight. SEAW (2009) recommends designing a frame column into the wall boundary capable of supporting tributary gravity loads, such that $R = 6$ can be used regardless of the tributary loads on the wall. SEAOC (2008) recommends $R = 6$ without the need to add a frame column where confined boundary elements are provided. This Guide recommends checking with the local jurisdiction. Note that ACI 318 and ASCE 7 define a bearing wall as any wall that supports more than 200 lb/linear ft of vertical load in addition to self-weight. This definition of bearing wall should not be confused with the Bearing Wall System designation of ASCE 7.

ASCE 7 specifies drift limits as a function of building height and Occupancy Category (**Table 2-1**). Drift is calculated using the design seismic forces E amplified by C_d (ASCE 7 § 12.8.6). C_d is 5 for both Bearing Wall and Building Frame Systems and is 5.5 for Dual Systems.

Structure	Occupancy Category		
	I or II	III	IV
$N \leq 4$	$0.025h_{sx}$	$0.020h_{sx}$	$0.015h_{sx}$
All other structures	$0.020h_{sx}$	$0.015h_{sx}$	$0.010h_{sx}$

Table 2-1 – Allowable Interstory Drift Ratios per ASCE 7.

Although cost considerations might suggest designing minimum-weight sections, such sections may be difficult to construct and might not perform well. Once the decision has been made to incorporate a wall in the building, formwork and reinforcement detailing will dominate costs. Selecting a thicker wall section is unlikely to have an appreciable effect on construction cost or functionality, but will reduce reinforcement congestion and improve earthquake performance. Although ACI 318 has no prescriptive minimum thickness, 8 inches is a practical lower limit for special structural walls. Construction and performance are generally improved if the wall thickness is at least 12 inches where special boundary elements are used and at least 10 inches elsewhere. Walls that incorporate coupling beams require a minimum thickness of approximately 14 inches to accommodate reinforcement, required cover, and bar spacing, although 16 inches is a practical minimum where diagonally reinforced coupling beams are used. Flanges and enlarged boundary sections are helpful to stabilize boundaries and anchor reinforcement from adjacent members.

See Section 5 for guidance on wall proportioning.

3. Principles for Special Structural Wall Design

Buildings designed according to the provisions of ACI 318 Chapter 21 and ASCE 7 are intended to resist earthquake motions through ductile inelastic response of selected members. For structural walls, the nature and extent of inelastic response will vary with wall layout and aspect ratio. A good design anticipates the inelastic mechanism and provides proportions and details in the wall that will enable it to respond as intended. The following sections summarize the key principles for the design of structural walls. Detailed design guidance is presented later in the Guide.

Slender versus squat walls

Expected behavior of walls depends partly on wall aspect ratio. Slender walls ($h_w/l_w \geq 2.0$) tend to behave much like flexural cantilevers. The preferred inelastic behavior mode of slender walls is ductile flexural yielding, without shear failure. In contrast, walls with very low aspect ratios ($h_w/l_w \leq 0.5$) tend to resist lateral forces through a diagonal strut mechanism in which concrete and distributed horizontal and vertical reinforcement resist shear. Wall behavior transitions between these extremes for intermediate aspect ratios. Shear yielding of slender walls generally is considered unacceptable because it reduces inelastic deformation capacity below expected values. Shear yielding of very squat walls is often accepted because such walls tend to have high inherent strength and low ductility demands.

3.1 Slender Walls

3.1.1 Select Intended Yield Mechanism

For slender walls, the design should aim to achieve ductile flexural yielding at the base of the wall. For slender coupled walls, the target mechanism should include ductile yielding of coupling beams over the height of the wall plus ductile flexural yielding at the base of the walls. Wall shear failure and failure of diaphragms and foundations generally should be avoided. See **Figures 2-9** and **3-1**.

Where the design intent is to have a single critical section for flexure and axial force, the designer should provide a distribution of strength over wall height that inhibits yielding at other critical sections. One approach is to design the selected critical section to have strength in flexure and axial closely matching the required strength, with some overstrength provided at other locations (**Figure 3-1**). Where this approach is used, the special details for ductile response can be concentrated around the selected critical section, with relaxed detailing elsewhere.

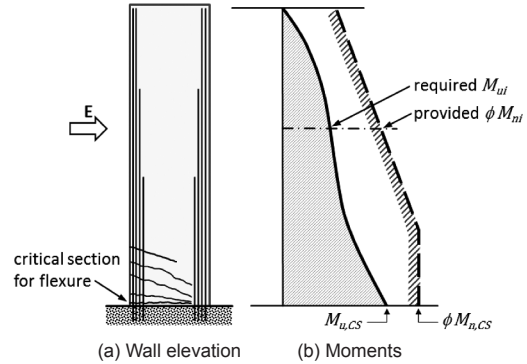

Figure 3-1 – Provided versus required flexural strength in a wall with a single critical section.

In some cases, alternative mechanisms have to be accepted. In very tall buildings, higher-mode response may cause some wall flexural yielding in intermediate stories in addition to the primary yielding mechanism. Detail such locations so they are capable of moderate ductility capacity. In highly irregular walls, including walls with irregular openings, it can be difficult to precisely identify and control the yielding mechanism. Some conservatism in the design of these systems can help achieve the desired performance.

3.1.2 Achieve Ductile Flexural Yielding

The intended critical section should be proportioned and detailed to be capable of multiple inelastic cycles. Key factors to improving cyclic ductility are (a) keep global compressive and shear stresses low; (b) design a confined, stable flexural compression zone; and (c) avoid splice failures.

A good wall design keeps the axial force well below the balanced point, such that flexural tension reinforcement yields before the flexural compression zone reaches the compressive strain capacity. Using ACI 318 terminology, compression-controlled walls (concrete reaches strain of 0.003 before tension reinforcement yields) should be avoided. It is noteworthy that the 1997 Uniform Building Code § 1921.6.6.4(3) (UBC 1997) limited wall axial force to $P_u \leq 0.35P_\theta$, which corresponds approximately to the balanced axial force in a symmetric wall. ACI 318 does not have any limits on the wall axial force.

Although ACI 318 permits factored shear on individual wall segments as high as $V_u = 10\phi\sqrt{f'_c}A_{cv}$, the flexural ductility capacity for such walls is reduced compared with identical walls having lower shear. This Guide recommends factored shear, calculated considering flexural overstrength (see Section 3.1.3), not exceed approximately $4\phi\sqrt{f'_c}A_{cv}$ to $6\phi\sqrt{f'_c}A_{cv}$ so that flexural ductility capacity is not overly compromised.

Inelastic flexural response may result in concrete compressive strains exceeding the unconfined crushing strain, typically taken as 0.003. If the flexural compression zone lacks properly detailed transverse reinforcement, concrete crushing and vertical reinforcement buckling at a section can result in a locally weakened “notch” where deformations concentrate, leading to relatively brittle behavior (**Figure 3-2**). Transverse reinforcement is necessary to confine the boundary, thereby enhancing concrete strain capacity and restraining longitudinal bar buckling. The special boundary element transverse reinforcement should comprise closely spaced hoops with cross-ties engaging peripheral longitudinal bars (**Figure 2-10**). In excessively thin walls, spalling of cover concrete can leave a relatively narrow core of confined concrete that can be unstable under compressive loading. This Guide recommends a minimum wall thickness of 12 inches for sections requiring special boundary elements unless tests on representative sections demonstrate adequate performance for thinner sections. Concrete cover over confinement reinforcement should be minimized such that cover spalling, if it occurs, will not result in a large reduction in section area. Good detailing practice also provides lateral support for every longitudinal bar in special boundary elements located within the intended hinge region. ACI 318 permits somewhat less stringent detailing (see Section 5.3.3).



Figure 3-2 – Concrete crushing and reinforcement buckling of inadequately confined wall, 2010 Chile earthquake.

Lap splices of vertical reinforcement can result in a locally strengthened section, such that yielding, if it occurs, may be shifted above or below the lap splice. Consequences of this shift should be considered. Lap splices subjected to multiple yielding cycles can “unzip” unless they are confined by closely spaced transverse reinforcement. For such splices, ACI 318 requires splice lengths at least 1.25 times lengths calculated for f_y in tension, with no requirement for confinement. This Guide recommends either that lap splices be moved out of the hinge zone or else be confined by transverse reinforcement.

Slender boundary zones can be susceptible to overall buckling under compressive loading (**Figure 3-3**). The problem can be exacerbated if the section was yielded previously in tension due

to loading in the opposite direction, leaving a more flexible pre-cracked section. ACI 318 has no limits on slenderness of special structural walls. This Guide recommends $l_u/b \leq 10$ within the intended hinge region and $l_u/b \leq 16$ (the limit prescribed in the 1997 Uniform Building Code) elsewhere.



Figure 3-3 – Wall buckling, 2011 Christchurch earthquake.

3.1.3 Avoid Shear Failure

Shear failure in a slender structural wall can lead to rapid strength loss at drifts below those anticipated in design. Shear failure also can compromise the wall axial strength. This is especially so for walls resisting high shear forces (exceeding around $10\sqrt{f'_c}A_{cv}$), because shear failure in such walls can occur by web crushing (**Figure 3-4**). For these reasons, the engineer should design slender walls to avoid shear failure.

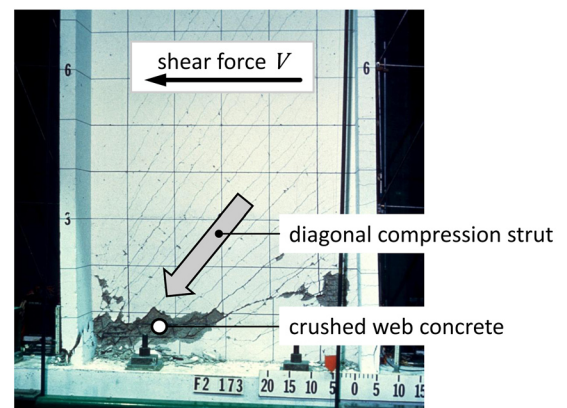

Figure 3-4 – Web crushing due to high shear force in laboratory test.

Design procedures in ACI 318 and ASCE 7 require consideration of multiple load combinations, and this invariably leads to flexural strength $M_{n,CS}$ that, under some load combinations, exceeds the required flexural strength $M_{u,CS}$ (**Figure 3-5**). Consequently, the lateral forces required to yield the wall in flexure, and the resulting wall shears, will be higher than the design values. A good practice is to amplify the design shear to account for this effect. One approach is to define a flexural overstrength factor $\phi_o = M_{n,CS}/M_{u,CS}$, which reflects how much

flexural overstrength is built into the wall, and to increase the design shears by this same factor. ACI 318 encourages this approach by permitting a higher strength reduction factor ϕ for shear when this approach is used (See Section 5.1). Anticipating that the wall will develop even higher flexural strength due to material overstrength and strain-hardening, SEAOC (2008) recommends $\phi_o = M_{pr,CS}/M_{u,CS}$. Note that $M_{n,CS}$ and $M_{pr,CS}$ depend on axial force, which varies for different load combinations and, for coupled walls, with loading direction. This Guide recommends using the load combination producing the most conservative value of ϕ_o .

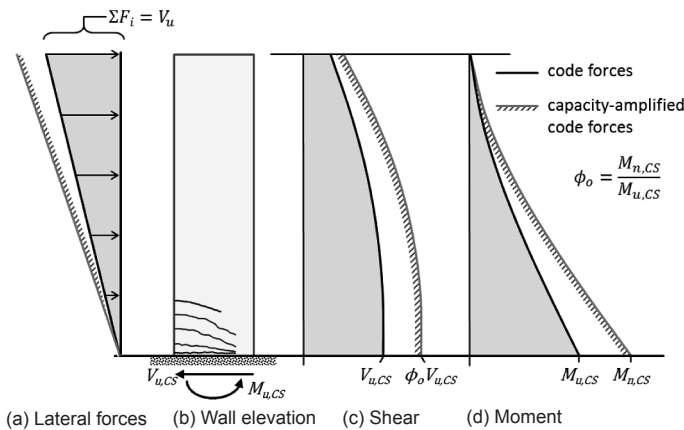

Figure 3-5 – Wall lateral forces, shears, and moments; code-prescribed forces and code-prescribed forces corresponding to development of nominal flexural strength.

In multi-story buildings, dynamic response produces ever-changing patterns of lateral inertial forces. Some prevalent force patterns shift the centroid of lateral forces downward, further increasing the shear forces corresponding to flexural strength at the critical section. To approximate this effect, the design shear can be increased to $V'_u = \omega\phi_o V_u$, where ω is a dynamic amplification factor. For buildings designed by the equivalent lateral force procedure (Section 4.1), SEAOC (2008) recommends $\omega = (0.9 + N/10)$ for buildings up to 6 stories and $(1.3 + N/30)$ for buildings over 6 stories. If shears are based on modal response spectrum analysis, ω need not exceed $(1.2 + N/50)$. N is the number of stories from base to roof, assuming typical story heights. Eurocode (2004) has an alternative formulation. ACI 318 and ASCE 7 do not require designing for this dynamic amplification factor.

Designing a wall to avoid shear failure requires consideration of several failure modes. Diagonal tension failure is evident in inclined cracks extending from the flexural tension boundary through the wall web, and it is controlled by provision of web horizontal and vertical reinforcement (Section 5.4). Diagonal compression failure is evident in crushing of the web near the flexural compression zone (**Figure 3-4**) and is controlled by limiting the maximum value of wall shear as a function of

wall area and concrete compressive strength. See Section 5.4. Sliding shear failure is evident in horizontal cracks and sliding along construction joints and is controlled by proper treatment of construction joints, including surface roughening and possibly intermittent shear keys, as well as placement of vertical reinforcement across the potential sliding plane (Section 5.5).

3.2 Squat Walls

Walls tend to have high inherent flexural strength and thus are prone to inelastic response in shear rather than flexural yielding. Contrary to slender walls, such behavior can provide sufficient post-yield stiffness and deformation capacity.

Squat walls are prone to two types of shear failure. “Shear yielding” within the wall web involves development of inclined cracks (**Figure 3-6**). Horizontal force equilibrium of segment **cde** requires distributed horizontal reinforcement providing force F_h . Moment equilibrium of segment **cde** about **e**, or segment **ab** about **b**, requires distributed vertical reinforcement providing force F_v . Thus, ACI 318 requires both vertical and horizontal reinforcement to resist shear in squat walls. “Shear sliding” tends to occur at construction joints, including the wall-foundation interface. Axial force N_u and distributed vertical reinforcement A_{vf} (including added dowels) provide a clamping force across the interface that resists sliding. Reinforcement A_{vf} is most effective if distributed. Thus, it may be preferred to distribute the flexural reinforcement uniformly without concentrated boundary elements. Reinforcement A_{vf} is more effective in resisting sliding if oriented at an angle of $\pm 45^\circ$, although this creates a constructability challenge. When concrete is placed against previously hardened concrete at this interface, ACI 318 requires the surface be clean and free of laitance. Intentional roughening increases sliding resistance.

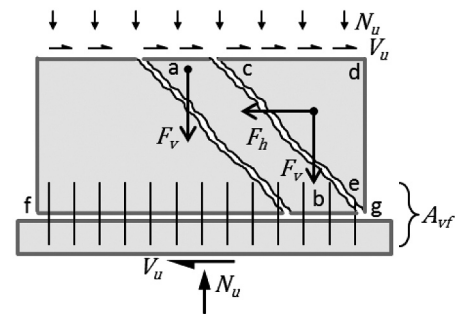

Figure 3-6 – Shear yielding and shear sliding in a squat wall.

3.3 Diaphragms and Foundations

The intent of U.S. building codes is that significant inelastic response will be limited to vertical framing elements of the seismic force-resisting system (for example, special moment frames, and special structural walls) that are detailed for ductile response. Diaphragms, foundations, and their connections, are intended to remain essentially elastic. Sections 6.3.2 and 6.3.3 of this Guide summarize ACI 318 and ASCE 7 requirements.

Foundation design practices vary. Some engineers design foundations for forces determined from load combinations including E without consideration of the capacity of vertical elements framing into the foundation. Others use capacity design principles to determine foundation forces based on the capacity of the vertical elements. Yet another practice for squat walls is to acknowledge the difficulty of tying down the foundation, and to accept foundation rocking. Rocking can impose large deformations on other components of the structure of the building that must be considered in design. Design requirements for rocking foundations are not included in this Guide.

4. Building Analysis Guidance

4.1 Analysis Procedures

ASCE 7 allows the seismic forces in a structural wall to be determined by three types of analysis: Equivalent Lateral Force Analysis, Modal Response Spectrum Analysis, and Seismic Response History Analysis. The Equivalent Lateral Force Analysis procedure is the simplest and can be used effectively for basic low-rise structures. This analysis procedure is not permitted for long-period structures (fundamental period T greater than 3.5 seconds) or structures with certain horizontal or vertical irregularities.

The seismic base shear V calculated according to Equivalent Lateral Force Analysis is based on an approximate fundamental period, T_a , unless the period of the structure is determined by analysis. Generally, analysis of moderate-to-tall structural wall buildings will show that the building period is longer than the approximate period, although the upper limit on the period ($C_u T_a$) applies for the base shear calculation. The longer analytical period will result in a reduced calculated base shear when the period is greater than T_s , often called the transition period. Per ASCE 7 Equations 12.8-3 and 12.8-4, the base shear in this range decreases as the considered period increases, up to the point where the minimum base shear equation governs.

Modal Response Spectrum Analysis is often preferred to account for the elastic dynamic behavior of the structure and to determine the calculated building periods. Another advantage of Modal Response Spectrum Analysis is that the combined modal base shear response can be less than the base shear calculated using Equivalent Lateral Force procedure. In such cases, however, the modal base shear must be scaled up to a minimum of 85 % of the Equivalent Lateral Force base shear.

For a Modal Response Spectrum or Seismic Response History Analysis, a 3-D computational model is typically used as an effective means of identifying the effects of inherent torsion in the lateral system as well as the directional interaction of flanged walls. For such analyses, code-prescribed accidental torsion forces typically are applied as static story torsions combined linearly with the dynamic results.

ASCE 7 § 12.5 specifies the requirements for the directions in which seismic forces are to be applied to the structure. Although the design forces for structural walls often may be based on the seismic forces applied in each orthogonal direction independently, it is common to apply the seismic forces using the orthogonal combination procedure of ASCE 7 § 12.5.3a. This combination considers 100 % of the seismic force in one direction combined with 30 % of the seismic force in the perpendicular direction. Multiple load combinations are

required to bound the orthogonal effects in both directions. To avoid excessive conservatism, the resulting structural wall demands typically are considered for each combination rather than being enveloped. The orthogonal force combination procedure is required for structural wall design only if that wall forms part of two or more intersecting seismic force-resisting systems and is subjected to axial load due to seismic forces acting along either principal plan axis equaling or exceeding 20 % of the axial design strength of the wall.

ACI 318 § 21.1.2.1 requires that the interaction of all structural and nonstructural members that affect the linear and nonlinear response of the structure to earthquake motions be considered in the analysis. Important examples include interactions with masonry infills (partial or full height), architectural concrete walls, stairwells, cast-in-place stairways, and inclined parking ramps. It is not always necessary to include these elements in the global model. Instead, global analysis results can be used to check whether interferences with nonstructural elements occur, and construction details can be modified as needed.

4.2 Stiffness Recommendations

When analyzing a structural wall, it is important to model appropriately the cracked section stiffness of the wall and any coupling elements, as this stiffness determines the building periods, base shear, story drifts, and internal force distributions. According to ACI 318 § 8.8.2, wall stiffness can be defined by (a) 50 % of gross-section stiffness; (b) $I_e = 0.70I_g$ if uncracked or $0.35I_g$ if cracked, and $A_e = 1.0A_g$; or (c) more detailed analysis considering the reduced stiffness under loading conditions. Actual stiffness of structural walls depends on reinforcement ratio, slip of reinforcement from foundations, foundation rotation, axial force, and other parameters. The flexural and axial stiffness values prescribed by ACI 318 are reasonable for many cases; shear stiffness, however, is typically as low as $G_c A_e / 10$ to $G_c A_e / 20$. ATC 72 (2010) provides additional guidance.

ACI 318 provides frame beam effective stiffness values, but these are not appropriate for typical coupling beams. Coupling beams are expected to sustain damage before significant yielding occurs in walls, leading to faster stiffness reduction. Coupling beam effective stiffness is further reduced because of concentrated end rotations associated with reinforcement slip from anchorage zones within the wall boundary. ATC 72 (ATC 2010) recommends taking $E_c I_e = 0.15E_c I_g$ with shear deformations calculated based on $G_c = 0.4E_c$ for $l_n/h \geq 2$ and $G_c = 0.1E_c$ for $l_n/h \leq 1.4$, with linear interpolation for intermediate aspect ratios.

The preceding recommendations intend to approximate secant stiffness to onset of yielding. Actual instantaneous

stiffness varies with time as a structure oscillates at varying amplitude. A nonlinear analytical model can approximate these instantaneous stiffness changes with time, but at considerably greater expense in modeling and computation. For additional guidance, see Deierlein et al. (2010).

Floor diaphragms can be modeled adequately as rigid elements if the effects of in-plane floor deformations are expected to be small. This is generally the case if the aspect ratio of the diaphragm is small, if the structural walls are evenly distributed across the diaphragm, and if there is not a significant stiffness discontinuity in the structural wall system. If these conditions are not met, realistic stiffness properties, including effects of any expected cracking, should be used to model in-plane diaphragm flexibility. This is especially important if the diaphragm is used for large shear transfer, such as at setbacks and podium levels (**Figure 2-5**). For additional guidance, see Moehle et al. (2010).

4.3 Effective Flange Width

When a flanged wall undergoes drift, the flanges on both the tension side and the compression side participate in resisting axial force and moment (**Figure 4-1**). Actual normal stresses in the flange decrease with increasing distance from the web because of shear lag. The flange contribution varies depending on deformation level and whether the flange is in tension or compression. Conventional practice is to define an effective flange width and assume that concrete and anchored longitudinal reinforcement within the effective width contribute fully to strength (except concrete cracks on the tension side). According to ACI 318 § 21.9.5.2, unless a more detailed analysis is performed, effective flange widths of flanged sections shall extend from the face of the web a distance equal to the lesser of one-half the distance to an adjacent wall web and 25 % of the total wall height above the level in question.

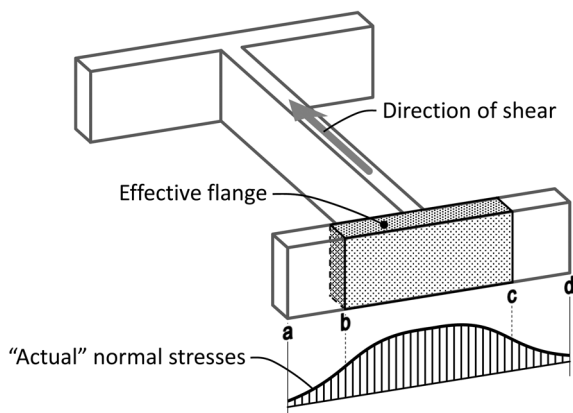

Figure 4-1 – Effective flange activation.

The preceding discussion applies to flexural strength calculation. For determination of tributary gravity loads, which resist uplift, use the full tributary flange width, not the effective flange width.

4.4 Foundation Modeling

Base restraint can have a significant effect on the behavior of structural wall buildings. ASCE 7 § 12.7.1 (Foundation Modeling) states “for purposes of determining seismic forces, it is permitted to consider the structure to be fixed at the base. Alternatively, where foundation flexibility is considered, it shall be in accordance with Section 12.13.3 or Chapter 19.” Unlike a moment frame lateral system, which may be detailed to be fixed or pinned at its base, a structural wall will always be fixed to the supporting foundation element. For this reason, structural walls are typically modeled as having a fixed base, with no further foundation modeling. However, the foundation elements supporting the structural wall need not be considered fixed with respect to the underlying soil. Foundation rocking and other soil-structure interaction effects are available for consideration and modeling, with guidance provided by ASCE 7 – Chapter 19 (Soil-Structure Interaction for Seismic Design). For buildings with multiple subterranean levels, a wall extending into the basement is more likely to be nearly fixed because it is “locked in” by the diaphragms, such that foundation rocking is less important.

5. Design Guidance

This section provides guidance for proportioning and detailing special structural walls and coupling beams. Different subsections of Section 5 apply, depending on wall geometry. **Table 5-1** identifies the subsections typically applicable to different walls or parts of walls. For “slender walls” and for “walls with $h_w/l_w \leq 2$,” the subsections are listed in the order in which they typically are applied for wall design.

Condition	Subsections
General	5.1, 5.2
Slender walls	5.3, 5.4, 5.5
Walls with $h_w/l_w \leq 2.0$	5.6, 5.4, 5.5, 5.3
Wall piers $l_w/b_w \leq 6.0$ and $h_w/l_w \leq 2.0$	5.7
Coupled walls and coupling beams	5.8 (and 5.3 - 5.7 as applicable)
Walls with discontinuities	5.9 and 5.10

Table 5-1 – Typical application of Section 5 to different walls or parts of walls.

5.1 Load and Resistance Factors

ASCE 7 Section 12 defines the load combinations applicable to special structural wall design. The load combinations require horizontal seismic effects to be evaluated in conjunction with vertical seismic effects, dead load, variable portions of the live load, and other applied loads such as soil pressure, snow, and fluids. The horizontal seismic effect is defined as $E_h = \rho Q_E$. The vertical seismic effect, defined as $E_v = 0.2S_{DS}D$, can increase or decrease the dead load effect.

The basic load combinations for strength design are:

$$(a) (1.2 + 0.2S_{DS})D + \rho Q_E + (0.5 \text{ or } 1.0)L + 0.2S \quad (\text{ASCE 7 } \S 12.4.2.3)$$

$$(b) (0.9 - 0.2S_{DS})D + \rho Q_E + 1.6H$$

The load factor on L is permitted to equal 0.5 for all occupancies in which L is less than or equal to 100 psf, with the exception of garages or areas occupied as places of public assembly. Otherwise, the load factor on L is 1.0.

To define the redundancy factor ρ , consider only vertical wall segments whose aspect ratio $h_w/l_w \geq 1$, where h_w = story height. If removal of one of these segments results in either a 33 % reduction in story strength or an extreme torsional irregularity, $\rho = 1.3$. Otherwise, $\rho = 1.0$. See ASCE 7 § 12.3.4.

For combined flexure and axial force in a wall, the strength reduction factor ϕ is determined using the same procedure as is used for columns. For this purpose, ε_t is defined as the net tensile strain in the extreme tension steel when the section reaches nominal strength ($\varepsilon_{cu} = 0.003$). If $\varepsilon_t \geq 0.005$, $\phi = 0.9$. If $\varepsilon_t \leq \varepsilon_y$ (taken as 0.002 for Grade 60), $\phi = 0.65$ for tied boundary

elements or 0.75 for spiral reinforced boundary elements. The value of ϕ is interpolated for intermediate values of ε_t .

For wall shear including shear-friction, ACI 318 § 9.3 allows $\phi = 0.75$, except $\phi = 0.6$ if the nominal strength V_n is less than the shear corresponding to development of the wall nominal flexural strength M_n . This Guide recommends designing slender walls so the design shear strength (ϕV_n) is at least the shear corresponding to development of the wall flexural strength. This typically is not practicable for squat walls; the use of $\phi = 0.6$ usually is not a significant penalty for squat walls given their inherent strength.

For diagonally reinforced coupling beams, $\phi = 0.85$ for shear. For conventionally reinforced coupling beams, $\phi = 0.75$ for shear and 0.9 for flexure.

5.2 Overall Proportioning

Initial structural wall sizing typically considers building seismic base shear V versus wall design shear strength ϕV_n . Building seismic base shear V is determined from ASCE 7 procedures as discussed in Section 4.1. When considering preliminary shear demands for individual walls, several amplification factors should be considered.

1. Redundancy factor ρ may amplify shear. See Section 5.1.
2. Torsion, both inherent and accidental, increases wall shear. Typical amplification factors, relative to the basic shear without torsion, are in the range 1.2 – 1.5.
3. Where shear is resisted by multiple vertical wall segments with different lengths, openings, and flanges, the total shear will be distributed nonuniformly among the segments. The amplification factor for individual segments can vary widely.
4. Designing for multiple load combinations invariably will result in wall flexural overstrength. For slender walls where a flexural yielding mode is desired, wall shears should be amplified commensurately. A factor of approximately 1.4 is typical. See Section 3.1.3.
5. Dynamic effects can amplify wall shears in multi-story buildings. For slender walls where a flexural yielding mode is desired, a dynamic amplification factor ω , defined in Section 3.1.3, can be applied.

The first three factors apply to most buildings, whereas the last two apply only to slender walls in multi-story buildings where the engineer intends wall flexural yielding to be the controlling inelastic mechanism.

ACI 318 § 21.9.4.4 defines the maximum design shear stress as $8\phi\sqrt{f'_c}$, although for any individual segment this can be as high as $10\phi\sqrt{f'_c}$. If the amplification factor of the fourth item above is applied, $\phi = 0.75$; otherwise, $\phi = 0.6$ (ACI 318 § 9.3.4). This Guide recommends targeting a lower design stress, in the range $4\phi\sqrt{f'_c}$ to $6\phi\sqrt{f'_c}$. A good first approximation of total required wall area in each direction is the amplified shear demand divided by the design shear stress.

Design of midrise and taller buildings may be controlled by drift limits (see Section 2.7 for ASCE 7 drift limits). For such buildings, spectral displacement S_d can be obtained, in inches, from the design response spectrum as $S_d = \left(\frac{T}{2\pi}\right)^2 S_a g = 9.8T^2 S_a$. Because most of these buildings will fall in the period range where $S_a = S_{D1}/T$, this expression can be recast as $S_d = 9.8TS_{D1}$ inches. For a fixed-base, uniform, flexural cantilever, the fundamental period required to meet the Interstory Drift Ratio limit is approximately $T \leq \frac{IDR}{21} \frac{h_n}{S_{D1}}$, where h_n and S_{D1} are in consistent units. The required total flexural stiffness of all walls is approximately $E_c I_e \geq 3.7 h_n W \left(\frac{S_{D1}}{IDR}\right)^2$. The basic assumptions of the expression are (a) fixed-base building, uniform over height, (b) flexural response in the first mode without torsion, and (c) inelastic drift can be estimated based on response of a linear oscillator having flexural stiffness EL_e . This expression can be used as a first approximation of the required wall properties for drift control. Values for Interstory Drift Ratio limits are in **Table 2-1**.

5.3 Flexure and Axial Force

Design for flexure and axial force involves preliminary proportioning, boundary element transverse reinforcement layout, analysis for P - M strength, and iterations to optimize the layout considering coordination of boundary element vertical and horizontal reinforcement and section strength.

5.3.1 Preliminary Proportioning

For uncoupled rectangular wall sections, preliminary sizing of the wall vertical reinforcement can be accomplished using the model of **Figure 5-1**, which assumes there is both distributed vertical reinforcement T_{s1} and boundary vertical reinforcement T_{s2} . Summing moments about C results in

$$M_{n,CS} = P_u x_p + T_{s1} j_1 l_w + T_{s2} j_2 l_w$$

Magnitude and location of P_u are determined from tributary dead loads including self-weight for the load combination shown; knowing location of P_u , moment arm x_p can be approximated. The internal moment arms for distributed and concentrated reinforcement can be approximated as $j_1 l_w = 0.4l_w$ and $j_2 l_w = 0.8l_w$. One approach is to select the minimum required distributed vertical reinforcement based on $\rho_l = 0.0025$, thereby approximately defining T_{s1} , and then use the equation above to find boundary element tension force T_{s2}

required to achieve target moment strength $M_{n,CS}$. (Note that squat walls sometimes require $\rho_l > 0.0025$; see Section 5.6.) Alternatively, if only distributed reinforcement is to be used, set $T_{s2} = 0$ and use the equation to solve for T_{s1} . Required distributed reinforcement is then $A_{st} = T_{s1}/f_y$, but not less than the minimum required distributed reinforcement. For flanged sections, reinforcement within the effective flange width in tension contributes to T_{s2} .

The preceding discussion assumes the wall moment strength is controlled by tensile yielding of vertical reinforcement, as recommended by this Guide. If moment strength is controlled by strength of the compression zone, a modified approach is required, and axial force P_u must be based on the load combination of ASCE 7 § 12.4.2.3 (see Section 5.1).

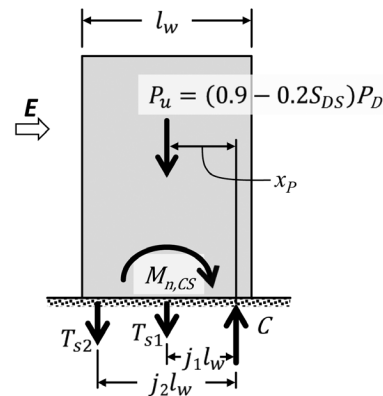

Note: This is a model showing forces to be considered for estimation of design tension forces T_{s1} and T_{s2} for wall without coupling.

$$M_{n,CS} = M_{u,CS} / \phi$$

Wall base shear not shown.

Figure 5-1 – Model for initial selection of flexural tension reinforcement.

It is good design practice to provide hoop reinforcement to confine the most heavily strained portion of the flexural compression zone and to provide lateral support of vertical reinforcement (**Figure 2-10**). If boundary elements are required (Section 5.3.3), ACI 318 § 21.9.6.4 and 21.9.6.5 require them to extend horizontally from the extreme compression fiber a distance at least the greater of $c - 0.1l_w$ and $c/2$, where c is the largest neutral axis depth calculated under combinations of P_u and M_u . Generally, P_u for this calculation is based on the load combination (a) from Section 5.1. **Figure 5-2** presents a chart for preliminary estimation of the neutral axis depth. If concentrated flexural tension reinforcement is provided in the boundary, it can be spread out within the confined region. If it is too congested, either the proportions of the wall can be reconsidered, or the confined region can be extended further into the flexural compression zone.

Having established preliminary proportions, the next step is to confirm P - M strength and neutral axis depth using section analysis.

5.3.2 P - M Strength Calculations

The strength calculations for structural walls resisting combined flexure and axial force directly match the calculations

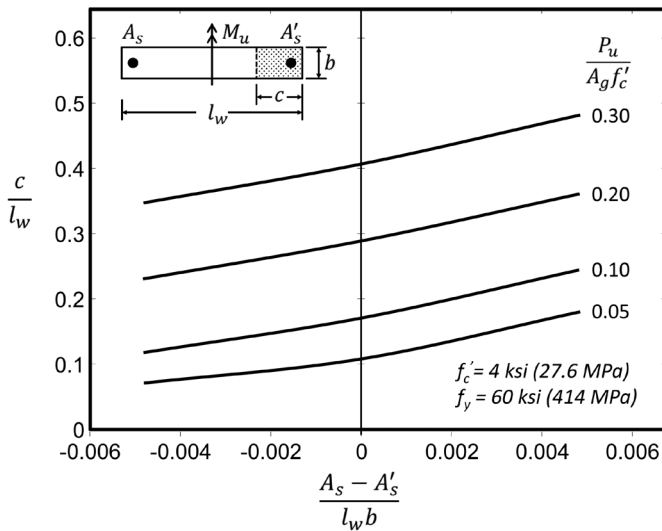

Figure 5-2 – Approximate flexural compression depth. For flanged sections, adjust A_s , A'_s , and b considering effective flange width.

for concrete columns. Specifically, the calculations assume linear strain distribution, idealized stress-strain relations for concrete and reinforcement, and material strain limits per ACI 318 § 10.2 and 10.3. All developed vertical reinforcement within effective flange widths, boundary elements, and the wall web must be included. P - M interaction software can facilitate the calculations. Also, the axial force P_u must be correctly located. Where axial force is based on tributary loads, with loads followed through the structure using hand calculations, usually the correct location of axial force is at the centroid of loads tributary to the wall, including self-weight. Where a computer model is used to establish axial force demand, the correct location usually is the location reported from the analytical model. Be aware that some computer programs automatically place P_u at the geometric centroid of the section. If this location is incorrect, resulting moments must be corrected by $M_u = P_u e$, where e is the eccentricity between the correct and assigned location of P_u .

Because wall geometry and concrete strength typically are defined before detailed analysis, the design for P - M resistance is generally a trial and error process using vertical reinforcement size and placement as the variables. Boundary element transverse reinforcement provides lateral support for the vertical reinforcement, so the design of both needs to be done in parallel. Boundary element detailing is considered next.

5.3.3 Boundary Elements

A boundary element is a portion along a structural wall edge or opening that is strengthened by longitudinal and transverse reinforcement. Where combined seismic and gravity loading results in high compressive demands on the edge, ACI 318 requires a special boundary element. Where compressive demands are lower, special boundary elements are not required, but boundary element transverse reinforcement still is required

if the longitudinal reinforcement ratio at the wall boundary, $A_{s,be} / A_{g,be}$ is greater than $400/f_y$. For clarity, this Guide refers to these latter elements as ordinary boundary elements (a term not used in ACI 318). **Figure 5-3** shows examples of special and ordinary boundary elements.

ACI 318 provides two methods for determining whether special boundary elements are required. The preferred method (ACI 318 § 21.9.6.2), which this Guide refers to as Method I, applies to walls or wall segments that are effectively continuous from base of structure to top of wall or segment and designed to have a single critical section for flexure and axial force, as in **Figure 3-1**. Some discontinuity over wall height is acceptable provided the wall is proportioned so that the critical section occurs where intended. To use the method, the seismic force-resisting system is first sized and then analyzed to determine the top-level design displacement δ_u and corresponding maximum value of wall axial force P_u . The flexural compression depth c corresponding to nominal moment strength $M_{n,CS}$ under axial force P_u is then calculated (**Figure 5-4**). If

$$c \geq \frac{l_w}{600 (\delta_u/h_w)} \quad (\text{ACI 318 Eq. 21-8})$$

where h_w refers to total wall height from critical section to top of wall, then special boundary elements are required.

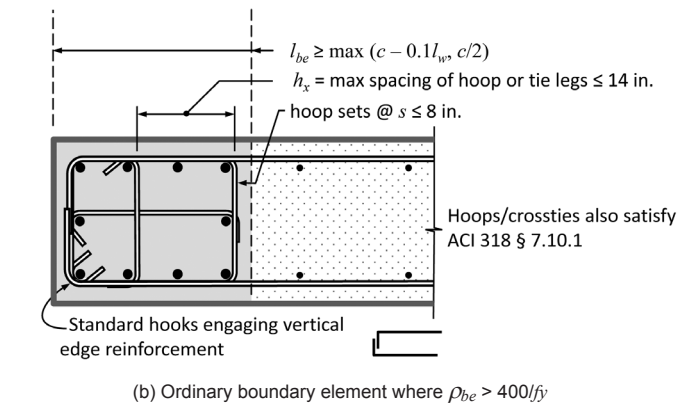
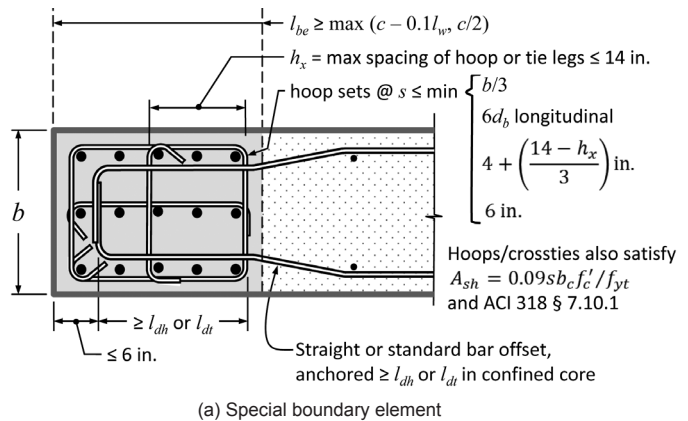

Figure 5-3 – Special and ordinary boundary elements.

Where special boundary elements are required by Method I, they must extend vertically above and below the critical section a distance not less than the greater of l_w and $M_{u,CS}/4V_{u,CS}$. The limit l_w is based on the expectation that cover spalling in a well-confined section typically will spread along a height approaching the section depth. The limit $M_{u,CS}/4V_{u,CS}$ defines the height above the critical section at which the moment will decrease to $0.75M_{u,CS}$, a value likely to be less than the spalling moment, assuming a straight-line moment diagram. Where the critical section occurs at or near the connection with a footing, foundation mat, pile cap, or other support, different requirements apply to the vertical extension of the special boundary element. See **Figure 5-5** and subsequent discussion.

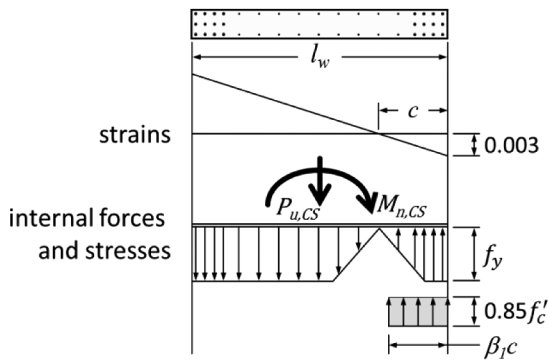

Figure 5-4 – Calculation of neutral axis depth c .

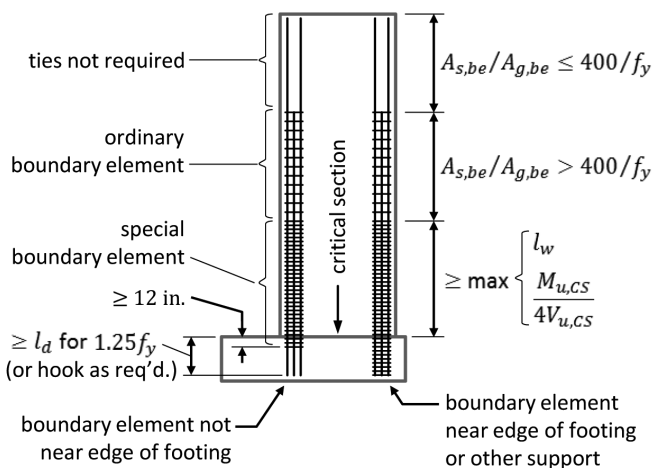
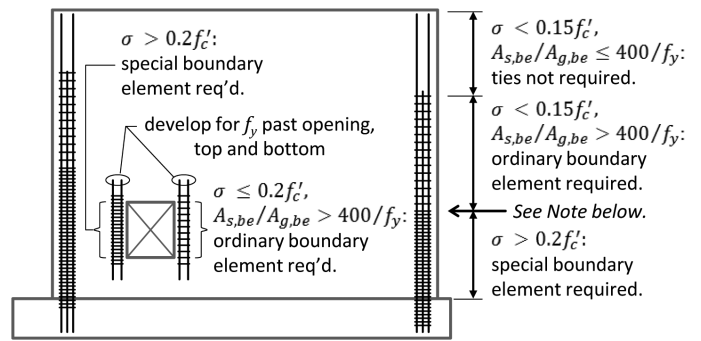

Figure 5-5 – Boundary element extensions for walls designed by Method I, for critical section at foundation interface. For ordinary and special boundary element details, see **Figure 5-3**.



Note: Requirement for special boundary element is triggered if $\sigma > 0.2f'_c$. Once triggered, the special boundary element extends until $\sigma < 0.15f'_c$.

Figure 5-6 – Boundary element requirements for walls designed by Method II. For extensions into foundations, see **Figure 5-5**. For ordinary and special boundary element details, see **Figure 5-3**.

The second method for determining if special boundary elements are required, which this Guide refers to as Method II, is based on nominal compressive stress (ACI 318 § 21.9.6.3). First, the seismic force-resisting system is sized and analyzed to determine axial forces and moments under design load combinations. Using a gross-section model of the wall cross section, nominal stress at wall edges is calculated from $\sigma = P_u/A_g + M_{ux}/S_{gx} + M_{uy}/S_{gy}$. Special boundary elements are required at an edge if nominal stress exceeds $0.2f'_c$. If a special boundary element is required, it must be continued vertically (upward and downward) until compressive stress drops below $0.15f'_c$. See **Figure 5-6**. Although Method II can be used for any wall, the preferred use is for irregular or discontinuous walls for which Method I does not apply.

At the interface with a footing, foundation mat, pile cap, or other support, longitudinal reinforcement of structural walls must be fully developed in tension. Where yielding of longitudinal reinforcement is likely due to lateral drifts, the development length is calculated for $1.25f_y$ (ACI 318 § 21.9.2.3c); otherwise it is calculated for f_y (ACI 318 § 21.12.2). Where depth of foundation element precludes development of straight bars, standard hooks having l_{dh} calculated for $1.25f_y$ or f_y , as appropriate, are acceptable. The standard hook should extend full-depth in most cases. See **Figure 5-5**.

Where a special boundary element terminates at a footing, foundation mat, or pile cap, the special boundary element transverse reinforcement must extend at least 12 inches into the foundation element (ACI 318 § 21.9.6.4d). For any other support, or where a boundary element has an edge within one-half the footing depth from an edge of the footing (or mat or pile cap), the transverse reinforcement must extend into the support at least l_d , calculated for f_y in tension, of the largest longitudinal reinforcement (ACI 318 § 21.9.6.4d and 21.12.2.3). See **Figure 5-5**.

Confinement trigger for walls with single critical section

Method I was derived from the simplified model shown below. It assumes that displacement δ_u is due entirely to curvature ϕ_u centered on the wall critical section with plastic hinge length = $l_w/2$. Defining $\phi_u = \epsilon_{cu}/c$, and setting $\epsilon_{cu} = 0.003$, results in $\delta_u = (0.0015l_w h_w)/c$. Rearranging and rounding leads to the following familiar expression:

$$c \geq \frac{l_w}{600 (\delta_u/h_w)}$$

If c exceeds this value, confinement is required. δ_u from the Building Code is an expected value for the Design Basis Earthquake for 5% damping. Displacements may exceed δ_u because of dispersion around the expected value, stronger shaking (for example, at the Risk-targeted Maximum Considered Earthquake), or lower damping. The combination of these factors suggest that the coefficient 600 should be closer to 1000 if the objective is to avoid section failure. This subject is being evaluated by ACI 318 at the time of this writing.

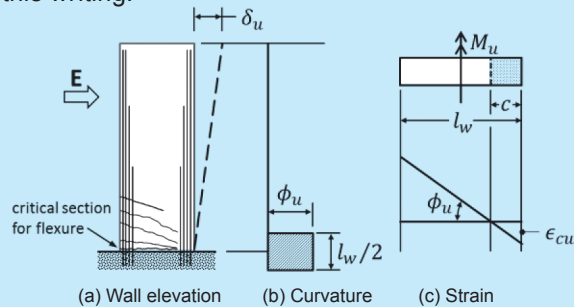

Figure 5-7 – Model to determine confinement trigger.

Where a special boundary element is required, ACI 318 § 21.9.6.4 requires it to extend horizontally from the wall edge a distance not less than the greater of $c - 0.1l_w$ and $c/2$ (Figure 5-3a). Flexural compression depth c is calculated at nominal moment strength $M_{n,CS}$ under maximum axial force P_u (Figure 5-4). In flanged sections, the special boundary element, if required, must include the effective flange width in compression and must extend at least 12 inches into the web. Special boundary elements must have transverse confinement reinforcement satisfying

$$A_{sh} = 0.09s_b c' f'_c / f_{yt} \quad (\text{ACI 318 Eq. 21-5})$$

Because f'_c and f_{yt} typically are selected independently of boundary element requirements, the remaining variables are confinement bar size and horizontal and vertical spacing of confinement hoop legs and crossties. The parameters for these variables are discussed in detail in Sections 5.3.4 and 7.1.

At wall boundaries where special boundary elements are not required, ACI 318 § 21.9.6.5 requires ordinary boundary elements if the boundary element longitudinal reinforcement ratio $A_{s,be}/A_{g,be} > 400/f_y$, where $A_{s,be}/A_{g,be}$ is the local ratio at the wall boundary only. Figure 5-3b shows requirements for ordinary boundary elements. Where $A_{s,be}/A_{g,be} \leq 400/f_y$, ACI 318 § 14.3.6 permits the section to be detailed without ties enclosing the vertical reinforcement. See Figure 5-5.

As discussed in Section 3.1.1, very tall wall buildings sometimes develop secondary flexural yielding near mid-height due to apparent higher-mode response. A challenge is that linear structural analysis, which is widely used, does not indicate directly whether such yielding is occurring. Nonlinear dynamic analysis can provide insight into this issue. Some designers define an intermediate boundary element that satisfies all requirements for special boundary elements except the volume ratio required by ACI 318 Eq. 21-5 is reduced by half; these intermediate boundary elements are extended into the potential secondary yielding zone. As a minimum, this Guide recommends that at least ordinary boundary elements extend through elevations that show high moment demands due to higher-mode response.

The illustration of Figure 5-5 is for the case where special boundary elements are required at the foundation interface. If special boundary elements are not required, ordinary boundary elements still are required if $A_{s,be}/A_{g,be} > 400/f_y$. Requirements over height are as shown in Figure 5-5, except there would be no special boundary elements, and transverse reinforcement is required to extend into the support only where it is near an edge of the support. In some walls, notably squat walls, even ordinary boundary elements are not required. This Guide recommends providing at least ordinary boundary elements at the wall boundary near the critical section for flexure.

5.3.4 Vertical Reinforcement Layout

The process for laying out wall vertical reinforcement is iterative, considering requirements for P - M strength and boundary element transverse reinforcement. One approach is as follows:

1. Determine the type of boundary element required (Section 5.3.3). If none required, go to step 4.
2. For special or ordinary boundary elements, determine the required boundary element length l_{be} (Figure 5-3), with c estimated from Figure 5-2 or from P - M analysis.
3. Select trial boundary element transverse reinforcement size (No. 3, 4, or 5) and vertical spacing. For special boundary elements, use ACI 318 Eq. 21-5 to determine A_{sh} , from which the number of hoop and crosstie legs in each direction is determined. Check all vertical and horizontal spacing requirements of Figure 5-3, as applicable.

- Select trial size and spacing of vertical reinforcement for entire structural wall section. If a boundary element is required, spacing of verticals in the boundary element is dictated by hoop and crosstie arrangement from step 3, with corner and at least alternate verticals restrained by a hoop or crosstie. Verticals outside the boundary element provide required ρ_t with spacing $s \leq 18$ inches.
- Determine P - M strength. If provided strength is inadequate or over-conservative, refine bar sizes and repeat step 3 or 4. If acceptable, continue.
- Use P - M analysis to check assumed boundary element extent in step 2. If inadequate or over-conservative, return to step 3 with new c . If acceptable, vertical reinforcement layout is complete.

Alternative iteration schemes also can lead to efficient designs. For example, some designers select boundary vertical reinforcement and spread it within required boundary length l_{be} , then layout transverse reinforcement to support the verticals and confine the core, and iterate until all requirements are met.

In step 5 above, the basic design requirement of ACI 318 is the same as for columns, that is, all combinations of (M_u, P_u) must be less than corresponding design values $(\phi M_n, \phi P_n)$. The value of ϕ is defined in Section 5.1. In addition, the maximum axial force cannot exceed the similar limit for columns (ACI 318 § 10.3.6). The usual approach is to use computer software to generate $\phi P_n - \phi M_n$ interaction diagrams and then check that M_u, P_u pairs for all load combinations fall within the design limits. Section 5.3.5 discusses the relevant load combinations.

5.3.5 Force Combinations from Modal Response Spectrum Analysis

As noted in Section 4.1, Modal Response Spectrum Analysis is a common method of determining wall design forces. This technique considers multiple vibration modes and combines the values of interest using either the square root of the sum of the squares or the complete quadratic combination method. Although the results from each mode correctly indicate the sign of calculated quantities, the square root of the sum of the squares and the complete quadratic combination results do not. For an uncoupled wall resisting lateral force in two orthogonal directions, there are four seismic load cases to be combined with the non-seismic loads for the P - M check:

$$\begin{array}{ll} P_u + M_{ux} + M_{uy} & P_u - M_{ux} + M_{uy} \\ P_u + M_{ux} - M_{uy} & P_u - M_{ux} - M_{uy} \end{array}$$

In contrast, the interactions in coupled walls result in significant induced axial forces. Consideration of all possible sign combinations results in eight possible seismic load cases:

$$\begin{array}{llll} +P_u + M_{ux} + M_{uy} & +P_u - M_{ux} + M_{uy} & -P_u + M_{ux} + M_{uy} & -P_u - M_{ux} + M_{uy} \\ +P_u + M_{ux} - M_{uy} & +P_u - M_{ux} - M_{uy} & -P_u + M_{ux} - M_{uy} & -P_u - M_{ux} - M_{uy} \end{array}$$

Again, these seismic forces are combined with dead, live, soil and snow loads per ASCE 7 load combinations (Section 5.1) for final structural wall design.

Sometimes, inspection of the eight possible sign combinations can identify combinations that are kinematically impossible and therefore require no further consideration. For example, consider the coupled planar structural wall shown in **Figure 5-8**. Lateral sway occurs with a single possible set of combined moments and axial forces. For the left-hand wall, axial tension is induced on the left edge of that wall. The reverse combination is shown in the right-hand wall, where maximum compression is induced on the right edge of that wall. These axial and flexural force sign pairings are determinant for these wall segments. Subtracting T_u from the left-hand wall or C_u from the right-hand wall would result in conditions that cannot occur; including these combinations would result in unnecessary wall flexural overstrength, which can cascade to increased design requirements elsewhere.

The sign-force combination of flanged and coupled structural walls is significantly more complex because of bi-directional interaction. Often the sign-force relationships revealed by an Equivalent Lateral Force Analysis can help understand the range of sign-force possibilities from the Modal Response Spectrum Analysis results.

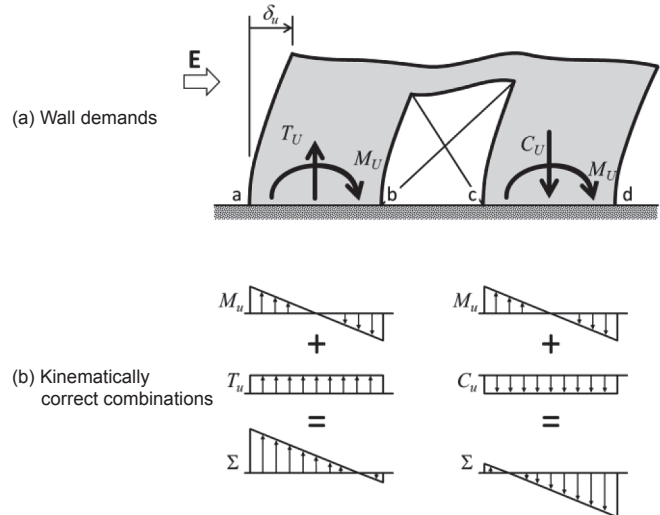

Figure 5-8 – Elevation of laterally displaced coupled wall system.

5.3.6 Termination of Vertical Reinforcement Over Wall Height

Vertical reinforcement can be terminated where it is no longer required to resist flexure and axial force. For this purpose, ACI 318 § 21.9.2.3 refers to ACI § 12.10, which defines bar

cutoff requirements for beams, but with $0.8l_w$ substituted for beam effective depth d . Hence, the basic requirements are that (a) terminated bars must be developed beyond points of maximum stress and (b) terminated bars must extend $0.8l_w$ beyond the point at which they are no longer required to resist flexure and axial force; the $0.8l_w$ extension is because diagonal shear cracks may shift flexural tension upward.

Figure 5-9 illustrates strict application of ACI § 12.10 to a wall, using a moment envelope as suggested in **Figure 3-1**. Bars **a** provide design strength ϕM_n sufficient to resist M_u at the critical section for flexure and axial force. If bars **b** are to be terminated, the requirements are (i) bars **b** must be developed for $1.25f_y$ above the critical section requiring these bars (1.25 factor required by ACI 318 § 21.9.2.3c); and (ii) bars **b** must extend at least $0.8l_w$ above the elevation where they are no longer required to resist flexure and axial force (in this case, $0.8l_w$ above the point where continuing bars **c** provide design strength $\phi M_n = M_u$). This process can be continued up the wall height, as in (iii) bars **d** must be developed for f_y above the critical section for bars **c**; and (iv) bars **d** must extend at least $0.8l_w$ above the point where continuing bars **e** provide required strength. In most cases, bar cutoffs will be controlled by the requirement to extend bars $0.8l_w$ past the point where they are no longer required to resist flexure and axial force, thereby simplifying design.

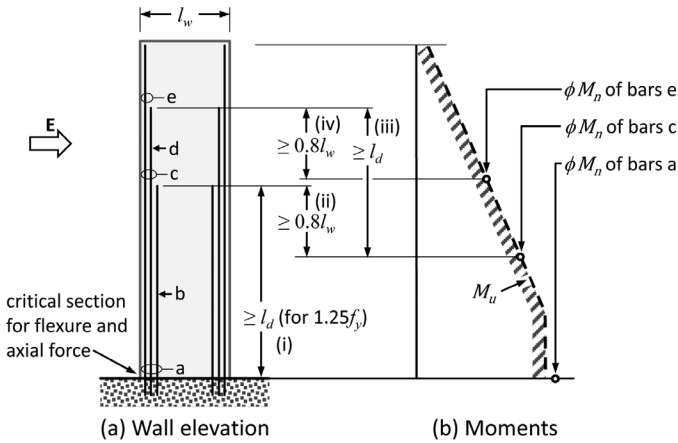

Figure 5-9 – Bar cutoffs for vertical reinforcement for idealized M_u moment diagram.

The aforementioned procedure seems unnecessarily onerous, especially considering that the wall moment diagram for a building responding to future earthquake shaking is not accurately known. A practice used by many design offices is to extend bars l_d above the floor where the bars are no longer required. This practice is not strictly in compliance with the aforementioned Building Code requirement, but it serves the intent to extend bars well past the point where they are no longer required for flexure, and seems to be a reasonable approach for design. This requirement is being evaluated by ACI 318 at the time of this writing.

ACI 318 § 12.10.5 addresses flexural reinforcement terminated in tension zones. Although not specifically exempted by the Building Code, it is understood that this provision is intended for beams. Common engineering practice does not apply this provision to the design of special structural walls.

5.4 Shear

Unlike the design of ordinary reinforced concrete structural walls, the design of special structural walls for shear does not consider the interaction of axial force and shear. ACI 318 § 21.9.4.1 defines the nominal shear strength as:

$$V_n = A_{cv} (\alpha_c \lambda \sqrt{f'_c} + \rho_t f_y) \quad (\text{ACI 318 Eq. 21-7})$$

where $A_{cv} = l_w b_w$, α_c is 3.0 for $h_w/l_w \leq 1.5$, is 2.0 for $h_w/l_w \geq 2.0$, and varies linearly between these limits; and $\lambda = 0.75$ for all-lightweight concrete, 0.85 for sand-lightweight concrete, and 1.0 for normalweight concrete. For design of an entire wall, the ratio h_w/l_w refers to the overall dimensions from base to top of wall. For design of a vertical wall segment within a wall, the ratio refers to the overall dimension of the wall or the dimensions of the vertical wall segment, whichever ratio is greater. The intent is that a vertical wall segment never be assigned a unit strength greater than that for the entire wall, although it can be assigned lower unit strength if its h_w/l_w is greater than that of the entire wall.

The basic design requirement is $\phi V_n \geq V_u$. Strength reduction factor ϕ is discussed in Section 5.1. This expression and the expression for V_n (ACI 318 Eq. 21-7) can be combined and solved for ρ_t , the required horizontal reinforcement ratio. Reinforcement composing ρ_t must be placed in two curtains if $V_u > 2A_{cv} \lambda \sqrt{f'_c}$, which is almost always the case. (This Guide recommends always using two curtains within the hinge region of a slender wall.) The reinforcement must provide a web reinforcement ratio not less than 0.0025 with maximum vertical spacing of 18 inches.

ACI 318 § 21.9.4.4 defines upper limits for shear strength of special structural walls. For all vertical wall segments resisting a common lateral force, combined V_n shall not be taken greater than $8A_{cv} \sqrt{f'_c}$, where A_{cv} is the gross combined area of all vertical wall segments. For any one of the individual vertical wall segments, V_n shall not be taken greater than $10A_{cv} \sqrt{f'_c}$, where A_{cv} is the cross-sectional area of concrete of the individual vertical wall segment. It is acceptable to interpret the common lateral force as either (a) the entire story shear, in which case the combined area refers to all walls or vertical wall segments in the story, or (b) the shear resisted by a single wall or a line of walls in a single plane, in which case the combined area refers to the area of walls or vertical wall segments in that plane.

If a special boundary element is required, ACI 318 § 21.9.6.4 (e) requires the horizontal shear reinforcement to extend to

within 6 inches of the edge of the wall and to be anchored to develop f_y in tension within the confined core of the boundary element using standard hooks or heads (**Figure 5-3a**). One option is to extend the web horizontal reinforcement continuously to near the wall edge. Another option is to lap the web horizontal reinforcement with the boundary element horizontal reinforcement such that the boundary element reinforcement serves as the wall shear reinforcement within the boundary element. This is only permitted if there is sufficient lap length and if the boundary element horizontal reinforcement provides strength $A_{sh}f_y/s$ parallel to the web reinforcement at least equal to the strength of the web horizontal reinforcement A_vf_y/s . In this case, it is permitted to terminate the web horizontal reinforcement without a standard hook or head. According to this alternative, the required reinforcement A_{sh} parallel to the web is the maximum of that required for confinement (ACI 318 Eq. 21-5) or shear (ACI 318 Eq. 21-7). It is not necessary to sum the two requirements.

5.5 Shear-Friction

The shear-friction provisions of ACI 318 § 11.6 are applicable where shear is transferred across an interface of two concrete volumes cast at different times. These provisions are intended to prevent sliding shear failure at such interfaces. This is a commonly applicable condition at the connection between walls and foundation and, for multi-story structural walls cast floor-by-floor, at the horizontal cold joint at each floor.

According to the shear-friction concept, the sliding resistance depends on interface roughness and the clamping force across the interface. Where reinforcement is perpendicular to the sliding plane, nominal shear strength is:

$$V_n = A_{vf}f_y\mu \quad (\text{ACI 318 Eq. 11-25})$$

A_{vf} refers to the distributed vertical reinforcement in the wall web; in a wall with boundary elements, A_{vf} can be conservatively calculated as if the distributed vertical web reinforcement continues uninterrupted into the boundary elements. Alternately, nominal shear-friction strength can be calculated per the equation given in ACI 318 R11.6.3. Where permanent net compression force N_u acts perpendicular to the sliding plane, the sliding shear strength is $V_n = (A_{vf}f_y + N_u)\mu$ with N_u positive in compression. Where transient net tension force $T_{u,net}$ acts perpendicular to the sliding plane, the sliding shear strength is $V_n = (A_{vf}f_y - T_{u,net})\mu$.

The basic design requirement is $\phi V_n \geq V_u$. Strength reduction factor ϕ is discussed in Section 5.1. Wall vertical reinforcement sized and located for P - M interaction resistance can serve double duty as shear-friction reinforcement. If that reinforcement proves insufficient to resist the interface shear, additional distributed vertical dowels can be placed along the wall

centerline, developed for f_y above and below the interface. ACI 318 also contains provisions for inclined bars, which can be more effective at resisting sliding, although bars would need to be inclined in both directions to resist alternating load directions.

V_n is not permitted to exceed the least of $0.2f'_cA_{cv}$, $(480 + 0.08f'_c)A_{cv}$, and $1600A_{cv}$.

In addition to reinforcement, ACI 318 § 21.9.9 requires that the interface be clean and free of laitance. If the surface is intentionally roughened to a full amplitude of $\frac{1}{4}$ inch, the friction coefficient can be taken as $\mu = 1.0\lambda$. Shear keys are an effective alternative where surface roughening to $\frac{1}{4}$ inch amplitude cannot be achieved. Otherwise, frictional resistance is reduced and $\mu = 0.6\lambda$.

5.6 Squat Walls

As noted at the beginning of Section 3, low-aspect-ratio (or squat) walls tend to have high inherent flexural strength compared with shear strength, such that it can be difficult to achieve a flexural yielding mechanism for aspect ratio h_w/l_w less than approximately 1. Furthermore, squat walls tend to resist lateral forces through a diagonal strut mechanism that differs considerably from the flexural mechanism of a slender wall. For these reasons, the design approach and the required details for squat walls differ from those of more slender walls. Design usually begins with shear design (Section 5.4), followed by checking for shear-friction (Section 5.5) and then combined flexure and axial force (Section 5.3).

Nominal shear strength is defined by ACI 318 Eq. 21-7 (See Section 5.4). In Eq. 21-7, α_c is 2.0 for $h_w/l_w \geq 2.0$, is 3.0 for $h_w/l_w \leq 1.5$, and varies linearly between these limits. The basic design requirement is $\phi V_n \geq V_u$. For many squat walls, especially those having $h_w/l_w < 1$, it will not be feasible to achieve shear strength greater than the shear corresponding to development of flexural strength, in which case the strength reduction factor is $\phi = 0.6$. The required horizontal reinforcement ratio ρ_t is determined from these expressions. As with slender walls, reinforcement composing ρ_t must be placed in two curtains if $V_u > 2A_{cv}\lambda\sqrt{f'_c}$. In addition, the distributed horizontal reinforcement must provide web reinforcement ratio not less than 0.0025 with maximum vertical spacing of 18 in. Finally, the upper limits of wall nominal shear strength ($8A_{cv}\sqrt{f'_c}$ and $10A_{cv}\sqrt{f'_c}$) apply as noted in Section 5.4.

In a squat wall, distributed vertical reinforcement is as important as distributed horizontal reinforcement in resisting shear (**Figure 3-6**). ACI 318 § 21.9.4.3 requires reinforcement ratio ρ_t for distributed vertical reinforcement to be at least equal to reinforcement ratio ρ_t for distributed horizontal reinforcement if $h_w/l_w \leq 2$.

Once the shear reinforcement design is completed, the next step is to check for shear-friction resistance at any construction joints where concrete is placed against hardened concrete. If additional reinforcement is required, either reinforcement ratio ρ_l can be increased or dowels can be added at the construction joint. See Section 5.5.

Next, the wall is checked for combined flexure and axial force using the procedures of Section 5.3. If vertical reinforcement is required in addition to the distributed reinforcement ρ_l provided for shear, then either add additional distributed reinforcement or add vertical reinforcement at the boundaries. These two approaches (distributed reinforcement or concentrated boundary reinforcement) are equally efficient in resisting moment, but distributed reinforcement is more effective in resisting sliding at construction joints. Requirements for boundary elements, if any, are illustrated in Figure 5-6.

ACI 318-11 versus IBC 2009 Wall Pier Provisions

This Guide follows wall pier provisions of ACI 318-11, which differ from those of IBC 2009. It is likely that future editions of the IBC will adopt the ACI 318-11 provisions. This Guide recommends checking with the local jurisdiction to determine applicable provisions.

5.7 Wall Piers

A wall pier is a relatively narrow vertical wall segment that is essentially a column, but whose dimensions do not satisfy requirements of special moment frame columns. According to ACI 318 §21.9.8, a vertical wall segment is to be considered a wall pier if $l_w/b_w \leq 6.0$ and $h_w/l_w \geq 2.0$, where b_w , l_w , and h_w refer to dimensions of the vertical wall segment. Design of wall piers follows the usual requirements for vertical wall segments, but additional requirements apply as noted below.

ACI 318 requires wall piers to satisfy the special moment frame requirements for columns contained in ACI 318 § 21.6.3, 21.6.4, and 21.6.5, which address splice type and location, confinement reinforcement, and shear strength requirements applicable to special moment frame columns. Alternatively, wall piers with $l_w/b_w > 2.5$ can be designed as follows.

- Design shear force V_u is either the shear corresponding to development of M_{pr} at both ends or Ω_0 times the shear determined by analysis of the structure for design load combinations including earthquake effects. Design strength ϕV_n is calculated according to the usual provisions for walls (Section 5.4). Although not required by ACI 318, it would be prudent to reduce shear strength if the section has net tension, similar to requirements for columns.

- Transverse reinforcement is required to be in the form of hoops except where only one curtain of distributed shear reinforcement is provided (permitted only if $V_u \leq 2A_{cv}\lambda\sqrt{f'_c}$, in which case it is permitted to use single-leg shear reinforcement with 180° bends at each end engaging boundary vertical reinforcement). Maximum spacing of transverse reinforcement is 6 inches. Transverse reinforcement must extend at least 12 inches above and below the clear height of the wall pier.
- Special boundary elements are to be provided if required by ACI 318 § 21.9.6.3.

For wall piers at the edge of a wall, ACI 318 requires horizontal reinforcement in adjacent wall segments above and below the wall pier, proportioned to transfer the design shear force from the wall pier into adjacent wall segments (Figure 5-10). First, determine the design shear force V_u in the wall pier. Then determine the nominal unit shear strength v_n (force per unit length) of the adjacent wall segment. The total length of the required horizontal reinforcement is $V_u/\phi v_n$, where ϕ is the applicable strength reduction factor for shear (Section 5.1).

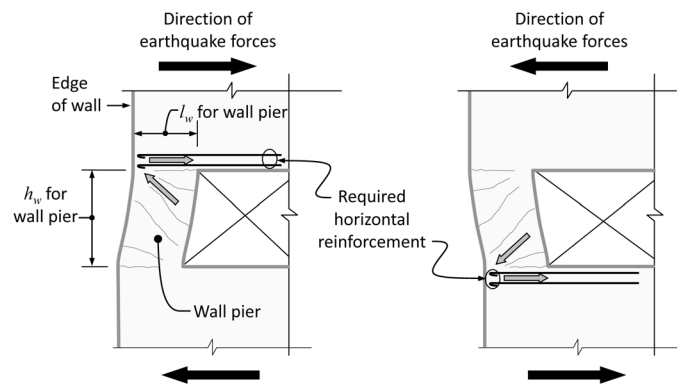

Figure 5-10 – Reinforcement required above and below wall pier.

5.8 Coupled Walls and Coupling Beams

Design of coupled special structural walls introduces design complexities beyond those encountered for uncoupled walls. Coupling beams often have relatively low aspect ratios and high deformation demands, requiring special details to achieve ductile performance. Coupling between walls results in axial force variations complicating their design. Coupling beam-wall connections require additional attention to avoid conflicts in reinforcing bar placement.

5.8.1 Coupling Beams

ACI 318 § 21.9.7 classifies coupling beams into three categories based on aspect ratio l_n/h and shear demand. As a practical matter, a fourth category for very deep beams is added here. Figure 5-11 illustrates the design options for these categories.

- a. **Coupling beams with $l_n/h \geq 4$** must satisfy proportioning and detailing requirements specified for beams of special moment frames, except certain dimensional limits are exempted. Such beams are considered too shallow for efficient use of diagonally placed reinforcement as allowed for deeper beams. Instead, flexural reinforcement is placed horizontally at top and bottom of the beam.
- b. **Coupling beams with $l_n/h < 2$ and $V_u > 4\lambda\sqrt{f'_c}A_{cw}$** are required to be reinforced with two intersecting groups of diagonally placed bars symmetrical about the midspan, unless it can be shown that loss of stiffness and strength of the coupling beams will not impair the vertical load-carrying ability of the structure, post-earthquake egress from the structure, or the integrity of nonstructural components and their connections to the structure. Implicit in the exception is the requirement for the engineer to demonstrate that the seismic force-resisting system satisfies code strength and drift requirements in the absence of the excepted coupling beams.
- c. **Other coupling beams** not falling within the limits of the preceding two bullets are permitted to be reinforced as either conventionally reinforced special moment frame beams or diagonally reinforced beams. In **Figure 5-11**, beams falling to the right of the dashed line likely can be designed efficiently as special moment frame beams, whereas those to the left probably are better designed with diagonal reinforcement.
- d. **Very low aspect ratio beams** are better designed using the strut-and-tie model of ACI 318 Appendix A. Design of these beams is not covered in this Guide.

The darkly shaded area of **Figure 5-11** defines the upper limit on beam design shear stress. The lightly shaded area indicates designs that are permitted by ACI 318 but that may have constructability problems because of reinforcement congestion.

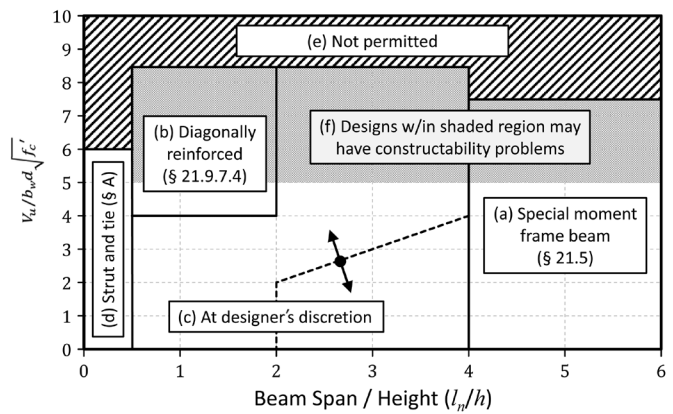

Figure 5-11 – Seismic coupling beam design space.

Beams designed as special moment frame beams (ACI 318 § 21.5) must have flexural reinforcement placed horizontally at top and bottom of the beam and hoop reinforcement that confines the end regions. **Figure 5-12** illustrates typical details. Because l_n/h is relatively small, longitudinal bars cannot be lapped and it may be easier to use closed hoops over the entire beam span rather than only $2h$ at each end. Skin reinforcement, if any, typically is terminated after short extension into the wall (~6 inches); alternatively, it can be developed into the wall in which case it contributes to beam flexural strength.

For beams reinforced with top and bottom longitudinal reinforcement, flexural and shear strengths are calculated according to conventional procedures. For flexure, the design requirement is $\phi M_n \geq M_u$, where M_u is determined from building analysis under design load combinations, and $\phi = 0.9$. For shear, the requirement is $\phi V_n \geq V_e$, where V_e is determined from equilibrium of the beam assuming it develops M_{pr} at both ends with distributed load w_u acting along the span (**Figure 5-13**). M_{pr} is probable moment strength, calculated using conventional ACI 318 assumptions except longitudinal reinforcement yield strength is assumed equal to $1.25f_y$. Within $2h$ from member ends, shear strength is based on

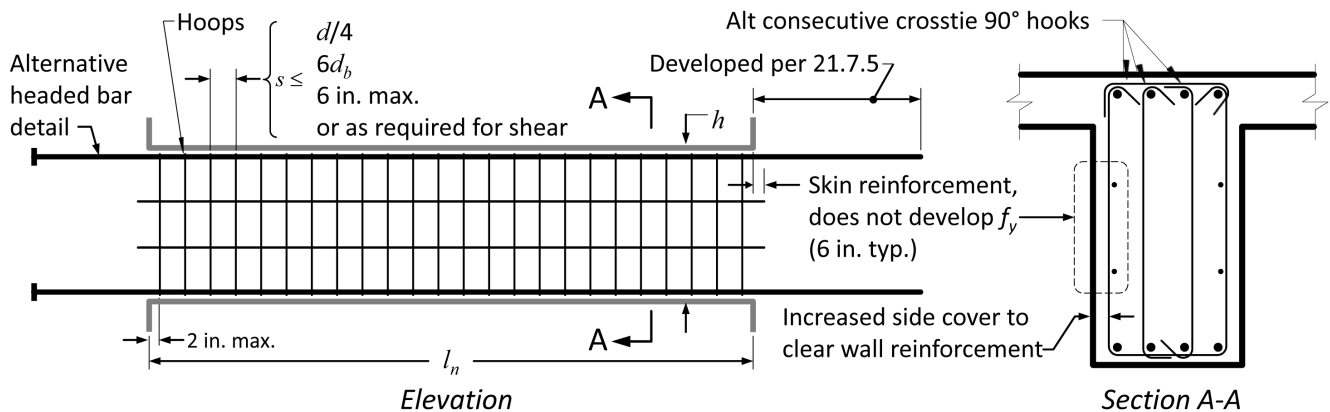

Figure 5-12 – Details for conventionally reinforced coupling beams.

$V_c = 0$, that is, $V_n = V_s = A_v f_y t d / s$, with an upper bound of $V_n = 10 \sqrt{f'_c} A_{cw}$ (ACI 318 § 21.9.4.5). Strength reduction factor for shear is $\phi = 0.75$ (ACI 318 § 9.3.2.3).

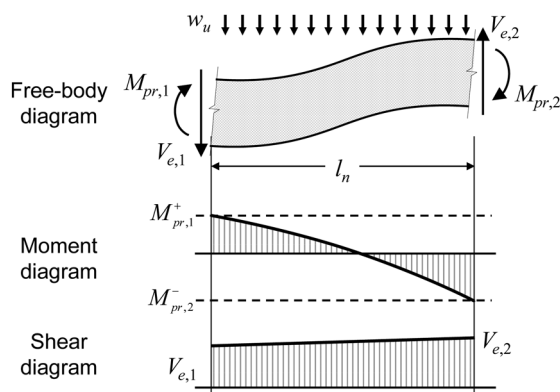

Figure 5-13 – Design shear for conventionally reinforced coupling beam. Reversed loading case also must be considered.

Figure 5-14 shows typical details for a coupling beam reinforced with two intersecting groups of diagonally placed bars symmetrical about the midspan. Each group of diagonal bars consists of a minimum of four bars provided in two or more layers. The diagonal bars are required to extend straight into the wall a distance at least 1.25 times the development length for f_y in tension. A challenge is avoiding interference between the diagonal bars and the boundary element transverse and longitudinal reinforcement. If an adjacent wall opening or edge (for example, at the top of the wall) requires the diagonal bar extension to be bent, additional reinforcement is required to resist the unbalanced force resulting from the change in reinforcement direction, similar to the requirement for offset bars in columns (ACI 318 § 7.8.1.3). This detail should be avoided where practicable. The minimum wall thickness to accommodate both wall and coupling beam reinforcement is around 14 inches, although 16 to 18 inches is more practical.

ACI 318 § 21.9.7.4 prescribes requirements for two reinforcement options. The first option is to confine individual diagonals using hoops and crossies such that corner and alternate diagonal bars are restrained in a hoop or crossie corner (**Figure 5-14a**). Confinement reinforcement along the entire diagonal length must satisfy the volumetric ratio requirements that apply at ends of special moment frame columns, assuming each diagonal as an isolated column with minimum cover over the diagonal cage. Maximum permitted hoop spacing along the diagonal is the smaller of s_o and $6d_b$ of the diagonal bars, where $s_o = 4 + (14 - h_x)/3$. Confinement reinforcement can be difficult to place along the free lengths of the diagonals and even more difficult where the diagonals intersect or enter the wall boundaries. See Section 7 for additional discussion.

The second option is intended to ease construction difficulties commonly encountered with the first option. By this option, hoops and crossies confine the entire beam cross section (**Figure 5-14b**). Confinement reinforcement along

the entire beam length must satisfy the volumetric ratio requirements that apply at ends of special moment frame columns, with maximum spacing along the beam span not exceeding 6 inches or $6d_b$ of the diagonal bars, and with spacing of crossies or legs of hoops around the beam cross section not exceeding 8 inches. Although the total amount of confinement reinforcement may be greater with this second option, the increased material costs are often more than offset by reduced labor costs.

Regardless of the option selected for the diagonally reinforced beam, longitudinal and transverse reinforcement is required around the beam section (**Figure 5-14**). The longitudinal reinforcement, typically No. 4 or No. 5 bars, should extend only a short distance into the wall boundary so that it will not develop significant tensile stress due to beam flexure. Transverse reinforcement varies depending on the option selected for confinement reinforcement. See ACI 318 § 21.9.7.4.

A diagonally reinforced coupling beam can be idealized as a truss with tension and compression diagonals along the axes of the diagonally placed reinforcement (**Figure 5-15**). Vertical equilibrium of the truss defines the shear strength V_n as:

$$V_n = 2A_{vd}f_y \sin \alpha \leq 10\sqrt{f'_c} A_{cw} \quad (\text{ACI 318 Eq. 21-9})$$

The inequality at the right side of Equation 21-9 is not from equilibrium but instead expresses the upper bound permitted by ACI 318, similar to the limit on wall shear (Section 5.4). Equation 21-9 requires determination of the reinforcement angle α . At least two layers of reinforcement are required in each diagonal bundle, so more than minimum cover is required to the centroid of the bundle. A good starting point is to assume the centroidal depth at the critical section is $jd = h - 8$ inches, from which α can be determined.

The basic strength design requirement for a diagonally reinforced coupling beam considers only shear; moment resistance is automatically provided by the idealized truss (**Figure 5-15**). The design requirement is $\phi V_n \geq V_u$, where V_u is determined from building analysis under design load combinations, and $\phi = 0.85$ (ACI 318 § 9.3.4(c)).

The main reinforcement must be fully developed in adjacent wall segments. For conventionally reinforced beams, ACI 318 § 21.7.5.2(b) typically governs for straight bars. For diagonally reinforced beams, the anchorage must be designed to develop $1.25f_y$ in tension. Headed reinforcement sometimes is used to shorten development lengths and facilitate construction. It should be noted that slip of reinforcement from adjacent wall segments is an important component of the overall deformation capacity of a coupling beam. Consequently, short headed bar anchorage can reduce deformation capacity of a coupling beam. Extending the headed bar beyond minimum development length l_{dt} will improve coupling beam deformation capacity.

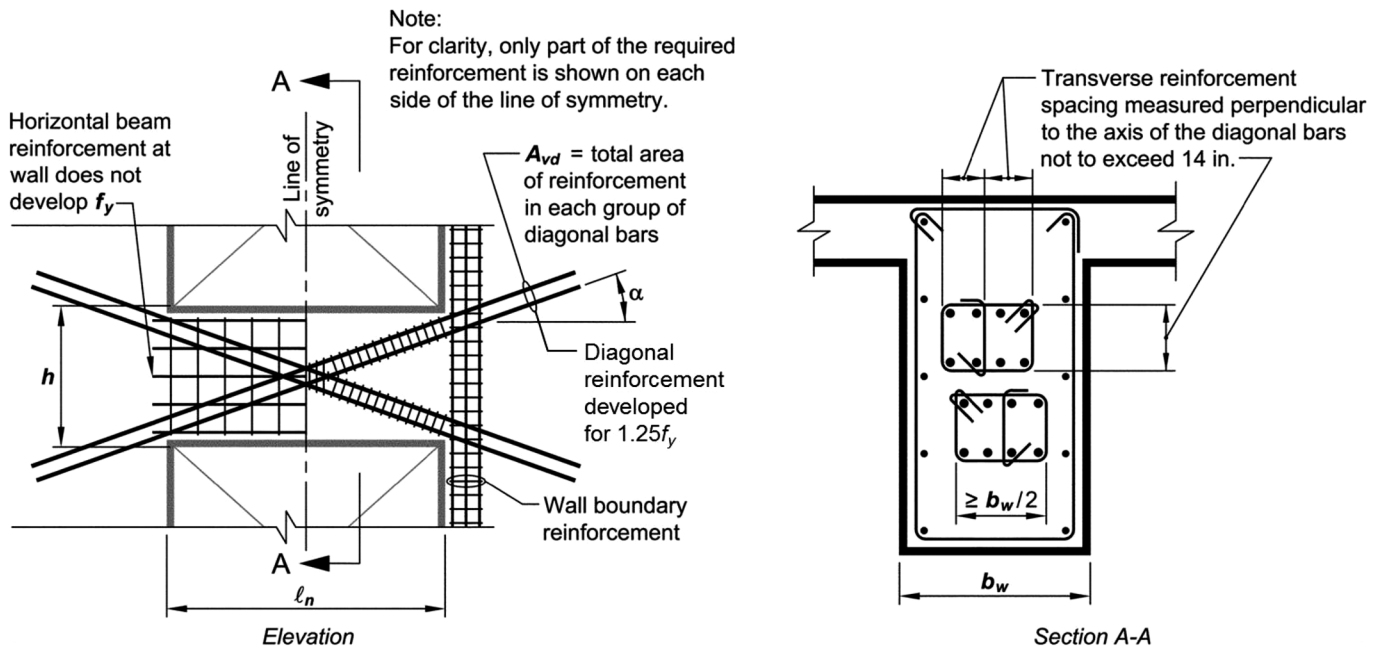

(a) Confinement of individual diagonals

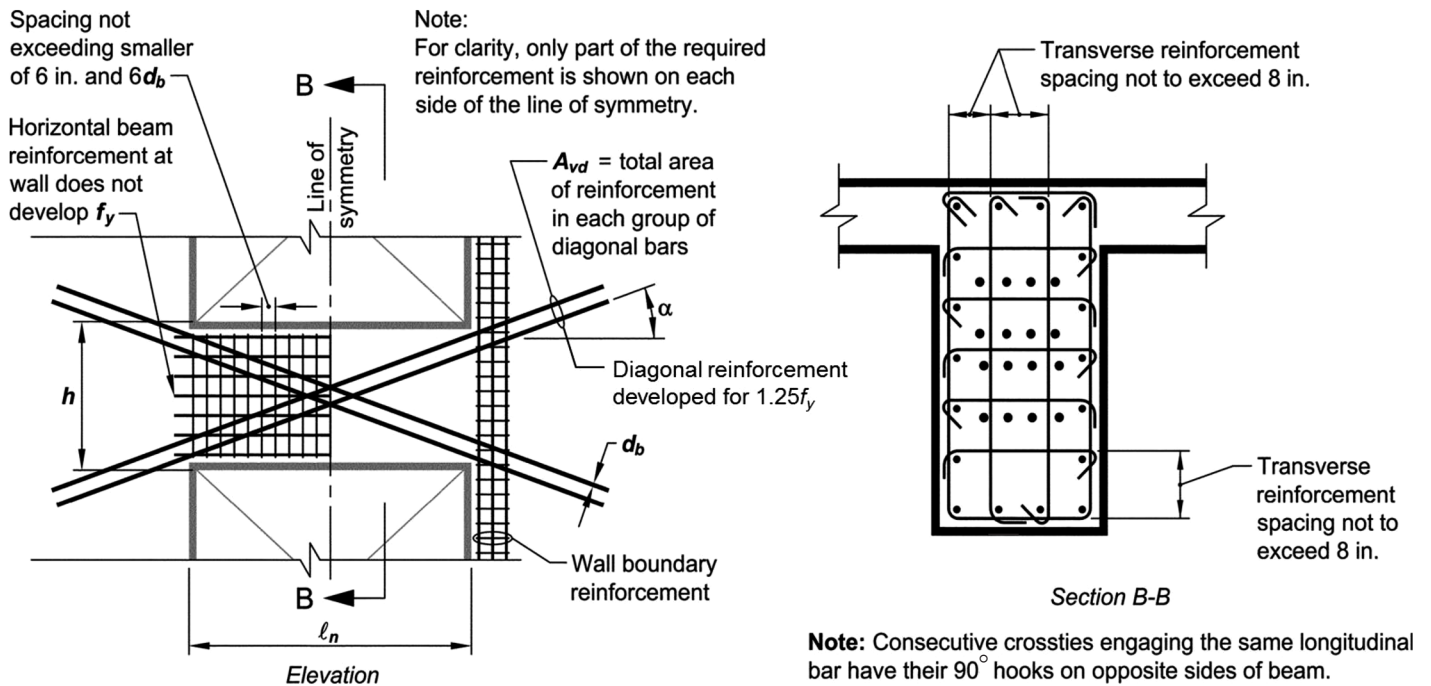

(b) Confinement of entire beam section

Figure 5-14 – Alternative details for diagonally reinforced coupling beams.

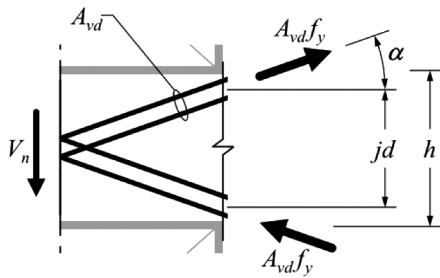

Figure 5-15 – Free-body diagram of half-span of a diagonally reinforced coupling beam. (Gravity loads not shown.)

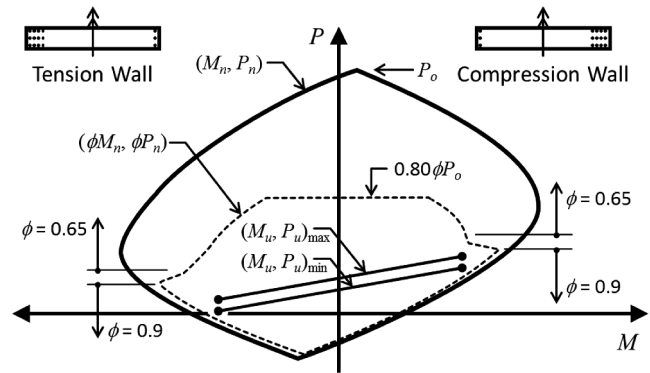

Figure 5-17 – P - M capacity check for coupled walls.

Alternative Coupling Beam Details

This Guide presents details prescribed by ACI 318. Several alternative detailing approaches have been proposed for use, including: hybrid beams combining elements of conventionally reinforced and diagonally reinforced beams; alternative arrangements of diagonally oriented reinforcement, and steel coupling beams. This Guide recommends checking with the local jurisdiction to determine acceptability of alternative designs.

5.8.2 Coupled Walls

Under lateral loading, coupling between walls causes variations in wall axial force in addition to moment and shear (Figure 5-8). The resulting combinations of moment and axial force produce increased flexural tension demand on some regions of the cross section (at a in Figure 5-8) and reduced flexural tension demand on others (at c in Figure 5-8). Similarly, flexural compression demands differ for the two coupled walls (d versus b in Figure 5-8). Individual walls designed for these combinations may have asymmetric boundary elements such as shown in Figure 5-16).



Figure 5-16 – Characteristic coupled wall cross sections.

Figure 5-17 illustrates the P - M capacity check for a pair of coupled walls symmetric about the system centerline. The solid curve corresponds to the P - M nominal strength, with the right side applicable to the compression wall and the left side applicable to the tension wall. The dashed curve is design strength (nominal strength reduced by strength reduction factor ϕ). Finally, the range of P - M demands under design load combinations including earthquake load is shown by the two inclined lines. This is an example of a well-designed wall with axial force well below the balanced point.

Redistribution of Internal Moments and Shears

Special structural walls and coupling beams are designed to have inherent ductility. As such, the designer should be able to take advantage of some moment redistribution relative to values obtained from elastic analysis without detrimental effect on building performance. For example, considering the coupled walls in Figure 2-9, elastic analysis will produce equal wall moments and shears for both the tension and compression walls. There may be some benefit (e.g., reduced reinforcement congestion or more economical foundation design) of redistributing moment from the tension wall to the compression wall. Likewise, coupling beam moments and shears will vary continuously over height, whereas there is some benefit to uniform beam design over several contiguous levels. Some building codes (e.g., Eurocode 8, 2004) permit wall moments in any vertical wall segment to be decreased by up to 30 %, provided the moment and proportional shear are picked up by other wall segments. Furthermore, coupling beam moments can be decreased up to 20 % at any level, provided the total coupling force over building height is not reduced. This approach is not explicitly recognized by U.S. building codes, but is deemed reasonable for design of coupled special structural walls.

Tests of coupled walls show that the compression wall is stiffer than the tension wall, such that moment (and shear) naturally “migrates” from the tension wall to the compression wall during earthquake shaking. Therefore, designing for force redistribution is both more efficient and more realistic.

5.9 Geometric Discontinuities

Where vertical discontinuities occur in multi-story walls, P - M interaction analysis must explicitly account for the change in vertical force paths. A common example occurs at a wall opening with solid panels above and below (Figure 5-18). For the design of the solid panel immediately above and below the opening, the P - M interaction check must exclude the portion of wall stacked with the opening. However, since this

is a solid panel, it can be assumed that plane sections remain plane. The effect of the opening likely is negligible beyond approximately l_h above and below the opening, where l_h is the width of the opening (Figure 5-18).

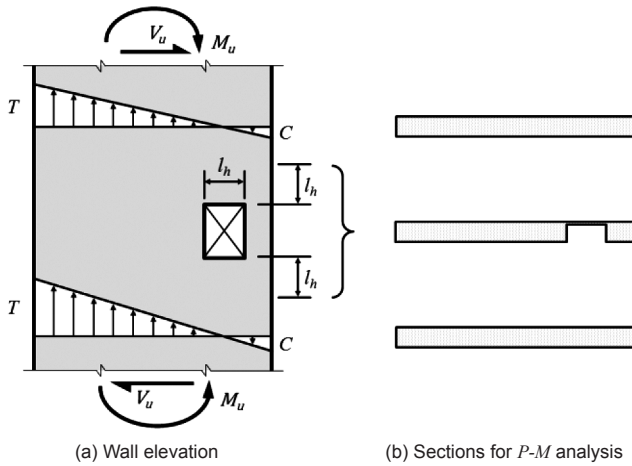

Figure 5-18 – P - M analysis at irregular opening.

In addition to transferring axial and flexural forces around the opening, designs need to consider transfer of shear forces around the opening. The procedure, illustrated in relation to Figure 5-10, is to determine how much shear is to be carried by the vertical wall segments on either side of the wall opening, and then design horizontal reinforcement to drag the required horizontal shears from these segments into the solid segments above and below.

Rows of openings in coupled walls sometimes are interrupted by solid wall segments at the roof level, at mechanical stories, or at basement walls, and these solid segments can be subjected to large demands. Figure 5-19 illustrates the case where coupled walls transmit moments and axial forces to a basement wall, which in turn distributes the forces into the foundation elements. Very large shear forces can develop in the basement wall between the two wall piers. This region should be analyzed to determine the shear forces on this “horizontal wall segment.” Boundary element vertical reinforcement should be well anchored into this segment, preferably full depth, and the panel should be well confined and generously reinforced for shear. Alternatively, if it is found to be beneficial to system performance, the designer should consider adding an opening to such areas to eliminate the discontinuity. These openings can have nonstructural infill to restore the programmatic intent.

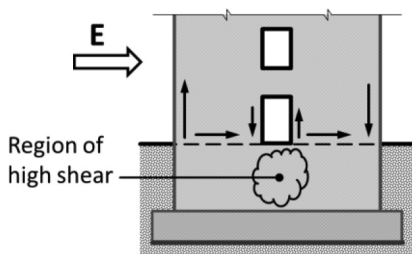

Figure 5-19 – Forces in solid wall below or above row of openings.

Strut-and-tie models can be useful to understand the flow of forces around wall irregularities. Figure 5-20 illustrates a highly irregular condition at the base of a wall for which a strut-and-tie model is useful. Wall moment and axial force from above are resisted primarily by tension and compression resultants at a and c . Shear from above is resisted primarily by panel $bcef$, producing diagonal compression strut bf , which requires tension tie be . The horizontal component of strut bf requires tension tie def , for which appropriate tension reinforcement should be provided. Panel $degh$ resists the majority of shear in the first story. ACI 318 Appendix A prescribes stress limits for struts, ties, and nodes of the strut-and-tie model. Given the irregular geometry, and lack of a clearly defined plastic-hinge region, determination of confinement requirements would have to be according to ACI 318 § 21.9.6.3 (described as Method II Section 5.3.3).

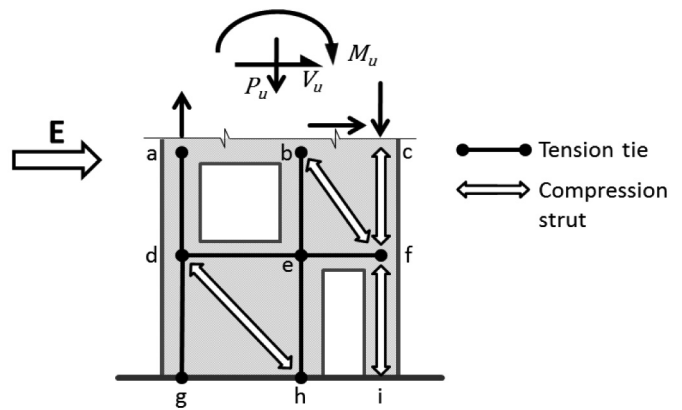

Figure 5-20– Strut-and-tie model.

5.10 Columns Supporting Discontinuous Walls

A column or wall pier supporting a discontinuous structural wall (for example, member fi in Figure 5-20) can be subjected to compressive overload due to axial force and moment transfer from the discontinuous wall. For columns, ACI 318 § 21.6.4.6 requires full-height column confinement for all stories beneath the discontinuous wall if the axial force related to earthquake effect exceeds $A_g f'_c / 10$. The confinement reinforcement must extend upward into the discontinuous wall at least the development length of the longitudinal reinforcement. If the column terminates at a wall, the confinement reinforcement must extend the same distance downward into the wall below. If it terminates at a footing or mat, extension 12 inches into the footing or mat is required, unless it terminates within one half the footing depth from an edge of the footing, in which case it must extend at least l_d (calculated for f_y) of the largest column longitudinal reinforcement. Similar requirements apply for wall piers (ACI 318 § 21.9.8).

6. Additional Requirements

6.1 Special Inspection

Proper construction of special structural walls is essential to ensuring that a building, once constructed, complies with the requirements of the code and the approved design. To foster proper construction, the IBC requires special inspections for most concrete buildings.

IBC Table 1704.4 requires periodic inspection to verify size and placement of reinforcing steel. Periodic inspection includes inspection of all completed reinforcing steel placement. Concrete also requires special inspections, including:

- Verifying use of required design mixture
- Inspecting formwork for location, dimensions, and debris
- Sampling fresh concrete for strength test specimens, performing slump and air content tests, and determining concrete temperature at time of placement
- Placing of concrete and shotcrete
- Curing temperature and techniques

The design professional for a building must prepare a statement of special inspections identifying the required inspections for construction of the building. The statement is to include the materials, systems, components, and work required to have special inspection; the type and extent of each special inspection; the type and extent of each test; additional requirements for seismic or wind resistance; and clarification of which inspections shall be continuous and which shall be periodic. The statement of special inspections must include inspection requirements for seismic force-resisting systems in structures assigned to Seismic Design Category C, D, E, or F. The only exception to this last requirement is for reinforced concrete buildings that are less than 25 ft in height above the grade plane and that are located on a site with design spectral response acceleration at short periods, S_{DS} , less than or equal to 0.5 g.

The special inspector must be a qualified person who demonstrates competence to the satisfaction of the building official for inspection of the construction. The special inspector is to furnish inspection reports to the building official and the design professional indicating whether work inspected was completed in conformance with approved construction documents. Discrepancies are to be brought to the immediate attention of the contractor for correction. If not corrected, they are to be brought to the building official and design professional prior to completion of that phase of the work.

A final report documenting required special inspections and correction of any discrepancies noted in the inspections also is to be submitted.

6.2 Materials

6.2.1 Concrete and Shotcrete

ACI 318 § 21.1.4 requires specified compressive strength, f'_c , of at least 3000 psi for structural concrete. Additional requirements apply where lightweight concrete is used (see ACI 318 § 21.1.4). Where high-strength concrete is used, the value of $\sqrt{f'_c}$ is restricted to an upper-bound value of 100 psi for any shear strengths or anchorage/development lengths derived from Chapters 11 and 12 of ACI 318. Chapter 21 of ACI 318 does not include this upper-bound value for determining the shear strength of structural walls or coupling beams, but this Guide recommends including it. Some jurisdictions impose additional restrictions on the use of high-strength concrete.

For some structures, specified concrete strength of structural walls is higher than that of the diaphragm/floor system, resulting in a weak slab sandwiched between two stronger wall sections. ACI 318 § 10.12, which allows column concrete compressive strength to be 1.4 times that of the floor system, is intended to apply only for axial force transmission in columns. Some jurisdictions deem this applicable for structural walls. This Guide, however, recommends that it be applied for moment and axial force transmission only where the wall is confined by slabs on all sides. Applying this for shear goes beyond the code intent and is not recommended. The higher wall strength can be maintained using a jump core or flying form system for the wall construction to precede the floor construction. Where concrete for the portion of the wall through the thickness of the floor system is placed with concrete for the floor system, the higher strength concrete should be puddled at these elements and extended 2 ft into the slab as allowed for columns in ACI 318 § 10.12.1.

Use of shotcrete for structural walls is governed by IBC § 1913. Where wall reinforcement is larger than No. 5 bars, or reinforcement spacing is less than 2½ inches for walls with single curtain or $12d_b$ in walls with two curtains of steel, the IBC requires preconstruction tests to demonstrate adequate encasement of the reinforcing bars.

6.2.2 Reinforcement

Deformed reinforcement resisting earthquake-induced flexural and axial forces in special structural walls and coupling beams must conform to ASTM A706 Grade 60 (ACI 318 § 21.1.5). Alternatively, ASTM A615 Grades 40 and 60 are permitted if A706 stress and strain requirements are met. The optional use of A615 reinforcement sometimes is adopted because it may

be more widely available and may be less expensive. Higher-strength longitudinal reinforcement, including ASTM A706 Grade 80, is prohibited by ACI 318-11 because of insufficient test data to demonstrate its use and concerns about higher bond stresses and increased buckling tendency. ACI 318 § 21.1.1.8 permits alternative material such as ASTM A706 Grade 80 if results of tests and analytical studies are presented in support of its use and approved by the building official.

Higher-strength reinforcement up to 100,000 psi nominal yield strength is permitted for design of transverse reinforcement. This reinforcement can reduce congestion problems especially for members using higher strength concrete. Where used, the value of f_{yt} used to compute the amount of confinement reinforcement is not to exceed 100,000 psi, and the value of f_{yt} used in design of shear reinforcement is not to exceed 60,000 psi except 80,000 psi is permitted for welded deformed wire reinforcement (ACI 318 § 11.4.2). The intent of the code requirement is to limit the width of shear cracks.

6.2.3 Mechanical Splices

Longitudinal reinforcement in special structural walls is expected to undergo multiple yielding cycles in prescribed locations during design-level earthquake shaking. If mechanical splices are used in these locations, they should be capable of developing nearly the tensile strength of the spliced bars. Outside yielding regions, mechanical splices, if used, can have reduced performance requirements.

ACI 318 classifies mechanical splices as either Type 1 or Type 2, as follows: (a) Type 1 mechanical splices conform to ACI 318 § 12.14.3.2, that is, they are to be capable of $1.25f_y$ in tension or compression, as required; (b) Type 2 mechanical splices are required to develop the specified tensile strength of the spliced bar. Where mechanical splices are used in special structural walls, only Type 2 mechanical splices are permitted within a distance equal to twice the member depth from sections where yielding of the reinforcement is likely to occur as a result of inelastic lateral displacements. Either Type 1 or Type 2 mechanical splices are permitted in other locations.

6.2.4 Welding

Welded splices in reinforcement resisting earthquake-induced forces must develop at least $1.25f_y$ of the bar and are not to be used within a distance equal to twice the member depth from sections where yielding of the reinforcement is likely to occur as a result of inelastic lateral displacements. Welding of stirrups, ties, inserts, or other similar elements to longitudinal reinforcement that is required by design is not permitted because cross-welding can lead to local embrittlement of the welded materials. Welded products should only be used where test data demonstrate adequate performance under loading conditions similar to conditions anticipated for the particular application.

6.3 Additional System Requirements

Structures assigned to Seismic Design Categories D, E, or F must also satisfy certain other ACI 318 Chapter 21 requirements, as summarized below.

6.3.1 Anchoring to Concrete

Anchors resisting earthquake-induced forces must conform to the seismic design requirements of ACI 318 § D3.3, which aim to provide either a ductile yielding mechanism in the anchor or attachment, or sufficient overstrength to reduce risk of failure. The provisions of D3.3 do not apply to the design of anchors in portions of structural walls that are intended to yield during design-level shaking.

6.3.2 Diaphragms

Structural diaphragms are required to satisfy requirements of ACI 318 § 21.11. For elevated diaphragms in buildings without vertical irregularities, the diaphragm forces are predominantly associated with transferring inertial forces from the diaphragm to the vertical elements of the seismic force-resisting system. ASCE 7 contains requirements for determining these diaphragm forces. For elevated diaphragms in dual systems or for buildings with vertical irregularities, the diaphragms also resist transfer forces associated with interaction among the different elements of the seismic force-resisting system. For buildings with a podium level (**Figure 2-5**), the diaphragm transmits overturning forces from above-grade structural walls to the basement walls or other stiff elements of the podium.

Diaphragm design should aim to produce a diaphragm capable of transmitting forces to vertical elements of the seismic force-resisting system without significant inelastic response in the diaphragm. For this reason, ASCE 7 requires collectors of diaphragms to be designed for forces amplified by the factor Ω_o , which is intended to account for structural overstrength of the building. ACI 318 § 9.3.4 contains additional requirements related to the strength reduction factor for diaphragm shear. Moehle et al. (2010) presents guidance for cast-in-place diaphragms.

6.3.3 Foundations

ACI 318 § 21.12.1 presents requirements for foundations, including specific requirements for the foundation elements as well as requirements for longitudinal and transverse reinforcement of walls framing into the foundation. Slabs-on-ground that resist seismic forces from walls must be designed as diaphragms according to ACI 318 § 21.11.

6.3.4 Members Not Designated as Part of the Seismic Force-Resisting System

Common design practice designates only some of the building framing to be part of the seismic force-resisting system. The remainder of the structural framing not designated as part

of the seismic force-resisting system, sometimes referred to as “gravity-only” framing, needs to be capable of safely supporting gravity loads while the building sways under maximum expected earthquake ground motions. Failure to provide this capability has resulted in building collapses in past earthquakes.

ACI 318 § 21.13 specifies design requirements for members not designated as part of the seismic force-resisting system. The requirements apply to columns, beams, beam-column connections, slab-column connections, and wall piers of “gravity-only” framing. In some cases, the requirements approach those for special moment frames designated as part of the primary seismic force-resisting system. In some buildings it may be more economical, and may improve performance, to spread the seismic force resistance throughout the building rather than concentrating it in a few specially designated elements.

7. Detailing & Constructability Issues

A special reinforced concrete structural wall relies on carefully detailed and properly placed reinforcement to ensure that it can maintain strength through multiple cycles of deformation beyond yield. Although a structural wall is considered a singular element, reinforcement modules within the wall are typically pre-tied and hoisted into the place as separate pieces (**Figure 7-1**). The pre-tied modules are spliced to create a fully interlocked reinforcement cage prior to closing the forms and casting the wall. Aspects of detailing to improve constructability and performance are described below.

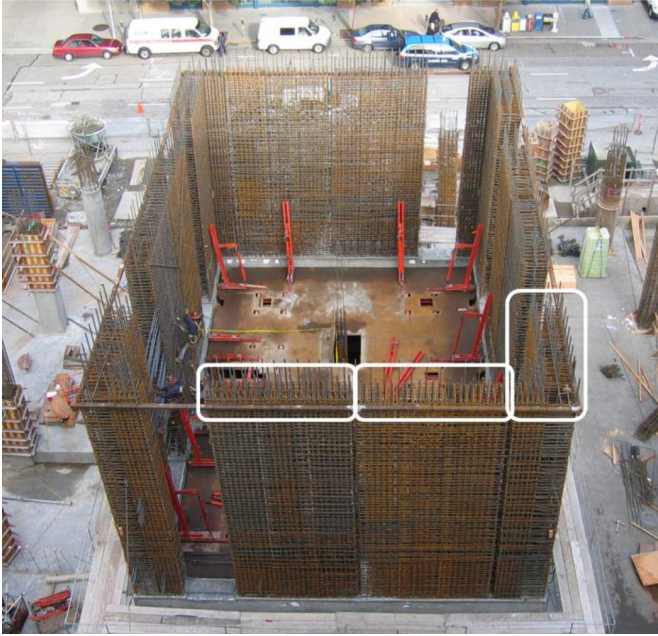

Figure 7-1 – Pre-tied modules (some modules encircled).

7.1 Boundary Element Confinement

As discussed in Section 5.3.4, the extent of a boundary element is integrally linked to the size and spacing of the vertical reinforcement within. Furthermore, a vertical bar is required in the corner of each hoop or crosstie bend. For this reason, it may be convenient first to determine the desired confinement layout prior to selecting vertical reinforcement. Fortunately, the confinement quantity and layout are defined by a closed-form equation that is independent of design forces.

The confinement variables typically at the designer's discretion are the confinement bar size, and the horizontal and vertical spacing of confinement hoop legs and crossties. Large diameter confining bars are desirable to reduce congestion, but bars larger than No. 5 are impractical because of required space for bar bends and hook tails. For higher strength steel, there also can be a limit to what bar size is bendable with locally available equipment.

Horizontal spacing of confinement legs, and hence the spacing of vertical reinforcement within the boundary element, will typically be much tighter (4 to 8 inches) than desired for the remainder of the wall. It is common to select vertical bar spacing within a boundary element that is a divisor of the vertical bar spacing in the unconfined portion of the wall. For example, if 12-inch spacing of vertical reinforcement is considered practical for the unconfined wall, the spacing of vertical bars within the boundary element should be 6 inches or 4 inches. This is beneficial because as vertical boundary bars drop off at higher elevations, the remaining bars align with and can be spliced to the 12-inch grid.

Boundary element reinforcement very much resembles a ductile column within the structural wall. A representative boundary element at the end of a planar wall is shown in **Figure 7-2**. Note that each crosstie has a 90° and a 135° hook, and these must be alternated end for end along both the length and the height.



Figure 7-2 – Boundary confinement for planar wall.

Some flanged walls require confinement throughout the flange, in which case confinement must extend at least 12 inches into the wall web (**Figure 7-3**). For very long confined boundary regions, one approach is to provide closely spaced confinement reinforcement in both directions at wall ends, with only closely spaced through-wall crossties along the middle extent of the wall. In this case, more widely spaced horizontal shear reinforcement in the web satisfying ACI 318 Eq. 21-5 can adequately confine the wall lengthwise.

Structural wall longitudinal reinforcement must extend into supporting elements and be fully developed for f_y or $1.25f_y$ in tension. See Section 5.3.3 for details. Where boundary elements are provided, equivalent horizontal confinement must be extended into the support. For structural walls on shallow foundations, this confinement must be extended 12 inches into the footing or mat. For structural walls supported

by all other elements, or where the edge of the boundary element is within one-half the footing depth from an edge of the footing, the confinement must extend into the support a distance equal to the development length of the largest vertical bar in the boundary. The critical subset of this category is boundary elements landing flush with the edge of a foundation or significant foundation step. This commonly occurs for structural walls that enclose elevator cores. The elevator pit dimensions commonly require a significant depression on one side of the structural wall. For this condition, it is recommended that the base of the depression be considered as the base of the structural wall. Vertical bars are therefore developed below the depression, and confinement is continued through the depth of the depression.

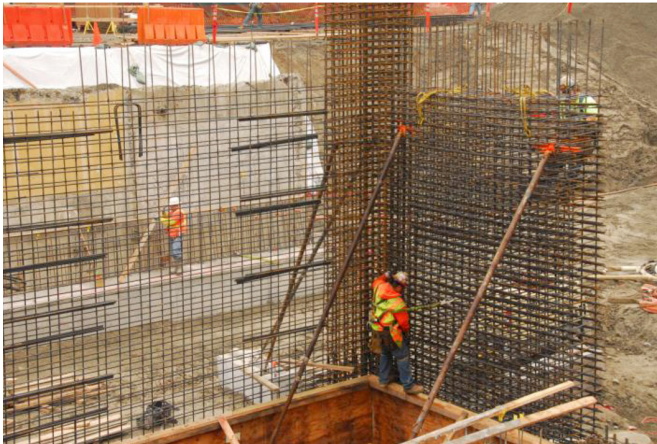

Figure 7-3 – Boundary confinement for wall flange.

7.2 Bar Compatibility

The critical location for detailed consideration of bar placement is the interface of wall ends with coupling beams. The main coupling beam reinforcement must extend into the wall end a length sufficient to fully develop the bar capacity (see Section 5.8.1). Bar compatibility becomes especially challenging where diagonal bars must extend into a heavily confined section. Full-scale pre-construction mockups can help identify solutions for particularly challenging designs (Figure 7-4).

To be reliably anchored, coupling beam longitudinal reinforcement must be placed inside the wall vertical reinforcement. For conventionally reinforced beams, this results in side cover over beam longitudinal reinforcement around 3 inches (Figure 5-12, Section A-A). Transverse reinforcement must be detailed for this increased cover so that the corner longitudinal bars are firmly placed in stirrup and crosstie bends. This decreased available width must also be considered when verifying clear horizontal spacing between longitudinal bars, a necessary measure to facilitate concrete placement and consolidation.

7.3 Anchorage of Web Reinforcement

To engage the full wall length to resist shear, horizontal shear reinforcement must be anchored at wall ends to develop the yield strength of the bar. For wall ends without special boundary elements, this requires hooking the horizontal reinforcement around the end vertical bars, or enclosing the wall end with U-stirrups having the same size and spacing as the horizontal reinforcement. For wall ends detailed as special boundary elements, horizontal reinforcement must be anchored to develop f_y within the confined core of boundary element, and extended to within 6 inches from the wall end. See Figure 5-3.



Figure 7-4 – Anchorage of diagonal reinforcement in heavily reinforced boundary element.

7.4 Bar Splices

According to ACI 318 § 21.9.2.3, reinforcement in structural walls is required to be developed or spliced for f_y in tension in accordance with ACI 318 Chapter 12, with some noted exceptions. At locations where yielding of longitudinal reinforcement is likely to occur as a result of lateral displacements, development and lap splice lengths of longitudinal reinforcement are required to be 1.25 times values calculated for f_y in tension. Lap splices, mechanical splices, and welded splices are permitted, with laps splices being the most common. As for all elements of concrete construction, reinforcing bars larger than No. 11 may not be lap spliced in structural walls. Mechanical and welded splices are required to satisfy ACI 318 § 21.1.6 and 21.1.7.

The first splice of vertical reinforcement typically occurs immediately above the foundation, where wall longitudinal reinforcement laps with dowel bars. These dowels provide the critical mechanism of transferring tension and shear forces from the structural wall to the foundation. All vertical reinforcement must be extended into the foundation a depth sufficient to be fully developed for tension. For constructability purposes, it is recommended that dowels with 90° hooks extend to the bottom of the foundation where they can be tied firmly to the foundation bottom reinforcement.

For structural walls with two curtains of reinforcement, it is preferred for the vertical reinforcement to be inside the horizontal reinforcement. This arrangement improves splice strength and buckling restraint for the verticals.

Horizontal reinforcement is always treated as “top-cast” reinforcement, requiring $\psi_t = 1.3$ for all development and lap splice length calculations. Splice locations might not be finalized until the contractor has determined the breakdown of pre-tied segments and the overall erection sequence including formwork operability. For structural walls with pre-tied segments, the horizontal reinforcement has the additional function of tying the pieces together in the final arrangement (Figure 7-1).

7.5 Miscellaneous Detailing Issues

As significant obstructing elements, structural walls must be closely coordinated with mechanical, electrical, and plumbing designs to enable the routing and distribution of these systems. Although it is preferable to spatially separate structural walls from the nonstructural components introduced by other trades, it is often necessary to provide blockouts and sleeves to allow for minor penetration of the structural walls. It is recommended to identify early those areas that are not available for penetrations, typically boundary elements, coupling beams, and the development zone of coupling beams in wall ends. Where penetrations occur, it is important to provide trim reinforcement around all edges. The exact layout and size of trim reinforcement should be selected to provide a complete load path for all local forces and to inhibit cracking of the walls along the sides of the penetrations.

The transfer of diaphragm forces between slabs and structural walls is ideally detailed in a distributed manner. Where this cannot be accomplished, due to large slab openings or very large transfer forces, horizontal collector elements must be created. At the wall-to-slab interface, this generally takes the form of large quantities of longitudinal reinforcement. Collector forces must be fully resolved into the wall end, requiring embedment in excess of a typical development length when the wall horizontal reinforcement is insufficient to provide a complete splice.

When steel elements are framed to structural walls, the connection detail typically takes the form of an embedded steel plate with deformed bars or headed studs welded to that plate and developed into the backing structural wall. This is a frequent occurrence for structural walls enclosing and forming an elevator core. Steel members will be required to separate multi-bank elevators, and to support elevator and counterweight rails. These members must be attached to the structural walls in very precise locations. To allow for tolerance in placement of the embedded steel connection plates, it is recommended to oversize the plates to allow for misplacement up to 3 inches without compromising the integrity of the connection.

7.6 Concrete Placement

Similar to column construction, the placement of structural wall concrete in high-aspect-ratio (height/width) forms inevitably includes the issues of concrete drop height, blind vibration, practical lift heights, and selection of a mixture with appropriate flowability. These issues need to be clearly discussed and coordinated with the contractor to ensure that the final product is fully consolidated, monolithic, and isotropic.

The intersection of slabs and structural walls is a region in which the placement sequence and resulting concrete strength needs to be closely considered. For multi-story construction, structural walls are typically cast to the underside of the slab above. The slab is cast over the top of the wall, and the wall construction resumes above. This results in a plane of slab concrete placed through the structural wall. The standard remedy is to place higher strength concrete in the slab over the top of the structural wall, extending two feet beyond the face of the wall. This method, typically called puddling, must be carefully scheduled with the slab pour to ensure that the high strength concrete is well integrated with the remainder of the slab.

The slip-form method of constructing structural walls eliminates this weakened plane at the structural wall-to-slab intersection. In this and other similar wall forming techniques, the structural wall is cast continuously through the depth of the slab, construction joints notwithstanding. Although this method avoids the potential for insufficient concrete strength in the structural wall, the slab-to-wall connection must be detailed to accommodate all force transfers. This critical location must transfer vertical shear from gravity forces in the slab and in-plane horizontal shear from diaphragm forces, and it must maintain integrity during drift-induced rotation of the slab-to-wall connection. Shear keys can help transfer shear forces at this otherwise smooth interface. Reinforcement details must be selected with due consideration of anticipated local deformations during earthquake shaking.

8. References

- ACI (2011). *Building code requirements for structural concrete (ACI 318-11) and commentary*, American Concrete Institute, Farmington Hills, MI.
- ASCE (2010). *Minimum design loads for buildings and other structures (ASCE/SEI 7-10)*, American Society of Civil Engineers, Reston, VA.
- ATC (2010). *Modeling and acceptance criteria for seismic design and analysis of tall buildings*, Report No. ATC 72-1, Applied Technology Council. Also available as Report No. PEER 2010/111, Pacific Earthquake Engineering Research Center, University of California, Berkeley.
- DBI (2009). “*Structural bulletin SB 09-09*,” Department of Building Inspection, City and County of San Francisco.
- Deierlein G.G., Reinhorn A.M., and Willford M.R. (2010). “Nonlinear structural analysis for seismic design: A guide for practicing engineers,” *NEHRP Seismic Design Technical Brief No. 4*, produced by the NEHRP Consultants Joint Venture, a partnership of the Applied Technology Council and the Consortium of Universities for Research in Earthquake Engineering, for the National Institute of Standards and Technology, Gaithersburg, MD, NIST GCR 10-917-5.
- Eurocode 8 (2004). *Eurocode 8: Design of structures for earthquake resistance, part 1, general rules, seismic actions and rules for buildings*, Comité Européen de Normalisation, European Standard EN 1998-1:2004, Brussels, Belgium.
- IBC (2009). *International Building Code*, International Code Council, Washington, DC.
- Moehle J.P., Hooper J.D., Kelly D.J., and Meyer T.R. (2010). “Seismic design of cast-in-place concrete diaphragms, chords, and collectors: A guide for practicing engineers,” *NEHRP Seismic Design Technical Brief No. 3*, produced by the NEHRP Consultants Joint Venture, a partnership of the Applied Technology Council and the Consortium of Universities for Research in Earthquake Engineering, for the National Institute of Standards and Technology, Gaithersburg, MD, NIST GCR 10-917-4.
- Osterle, R. G., Aristizabal-Ochoa, J. D., Shiu, K. N. and Corley, W. G. (1984). “Web crushing of reinforced concrete structural walls,” *ACI Journal*, American Concrete Institute 81 (3), pp. 231-241.
- SEAW (2009). “Special reinforced concrete shear walls as building frame systems for mid- and high-rise buildings,” White Paper 1-2009, Earthquake Engineering Committee, Structural Engineers Association of Washington.
- SEAOC (2008). “Reinforced concrete structures,” Article 9.01.010, *SEAOC blue book – Seismic design recommendations*, Seismology Committee, Structural Engineers Association of California.
- UBC (1997). *Uniform Building Code*, International Conference of Building Officials, Whittier, CA.

9. Notations and Abbreviations

A_{cv}	gross area of concrete section bounded by web thickness and length of section in the direction of shear force considered, in. ²	d	distance from extreme compression fiber to centroid of longitudinal tension reinforcement, in.
A_{cw}	area of concrete section of coupling beam resisting shear, in. ²	d_b	nominal diameter of bar, in.
A_e	effective cross-sectional area, in. ²	D	the effect of dead load
A_g	gross area of concrete section, in. ²	e	eccentricity of axial load relative to geometric centroid of section, measured in the plane of the wall, in.
$A_{g,be}$	gross area of wall boundary containing longitudinal reinforcement $A_{s,be}$, in. ²	E	effects of earthquake, or related internal moments and forces
A_s	area of longitudinal tension reinforcement in boundary element, in. ²	E_c	modulus of elasticity of concrete, psi
A'_s	area of longitudinal compression reinforcement in boundary element, in. ²	E_h	the horizontal seismic load effect defined in ASCE 7
$A_{s,be}$	total area of longitudinal reinforcement at wall boundary, in. ²	E_v	effect of vertical seismic input
A_{sh}	cross-sectional area of transverse reinforcement within spacing s and perpendicular to dimension b_c , in. ²	f'_c	specified compressive strength of concrete, psi
A_{st}	total area of longitudinal reinforcement, in. ²	f_y	specified yield strength of reinforcement, psi
A_v	area of shear reinforcement within spacing s , in. ²	f_{yt}	specified yield strength of transverse reinforcement, psi
A_{vd}	total area of reinforcement in each group of diagonal bars in a diagonally reinforced coupling beam, in. ²	F_h, F_v	horizontal and vertical forces in squat wall, lb
A_{vf}	area of shear-friction reinforcement, in. ²	F_i	design lateral force of level i , lb
b	width of compressive face of member, in.	g	gravity acceleration, in./s ²
b_c	cross-sectional dimension of member core measured to the outside edges of the transverse reinforcement composing area A_{sh} , in.	G_c	shear modulus of concrete, psi
b_w	web width or wall thickness, in.	h	overall thickness or height of member, in.
c	distance from extreme compression fiber to neutral axis, in.	h_n	height from base to roof, in.
C	flexural compression force, lb	h_{sx}	the story height below Level x
C_d	deflection amplification factor defined in ASCE 7	h_w	height of entire wall from base to top, or clear height of wall segment or wall pier considered, in.
C_u	coefficient for upper limit on calculated period defined in ASCE 7, or flexural compression force, lb	h_x	maximum center-to-center horizontal spacing of crossties or hoop legs on all faces of the boundary element, in.
		H	effects of soil, water in soil, or other materials
		I_e	effective moment of inertia, in. ⁴
		I_g	moment of inertia of gross concrete section about centroidal axis, neglecting reinforcement, in. ⁴

IDR	inter-story drift ratio	N_u	factored axial force normal to cross section occurring simultaneously with V'_{us} , to be taken as positive for compression and negative for tension, lb
j_1, j_2	coefficients defining horizontal distances between centroids of flexural compression force and flexural tension forces T_s , T_{s1} and T_{s2}	P_D	axial force due to dead load D , lb
l_{be}	length of boundary element, in.	P_n	nominal axial strength of cross section, lb
l_d	development length in tension of deformed bar, in.	P_o	nominal axial strength at zero eccentricity, lb
l_{dh}	development length in tension of deformed bar with a standard hook, measured from critical section to outside end of hook, in.	P_u	factored axial force; to be taken as positive for compression and negative for tension, lb
l_{dt}	development length in tension of headed deformed bar, measured from the critical section to the bearing face of the head, in.	$P_{u,CS}$	value of P_u at the critical section for flexure and axial force, lb
l_h	width of opening, in.	Q_E	effect of horizontal seismic (earthquake-induced) forces
l_n	length of clear span measured face-to-face of supports, in.	R	response modification coefficient
l_u	unsupported length of compression member, in.	s	center-to-center spacing, in.
l_w	length of entire wall or length of wall segment or wall pier considered in direction of shear force, in.	s_o	center-to-center spacing of transverse reinforcement, in.
L	the effect of live load	S	the effect of snow load
M_n	nominal flexural strength at section, in.-lb	S_a	spectral acceleration, g
$M_{n,CS}$	value of M_n at the critical section for flexure and axial force, in.-lb	S_d	spectral displacement, in.
M_{pr}	probable flexural strength of member, with or without axial force, determined using the properties of the member at the joint faces assuming a tensile strength in the longitudinal bars of at least $1.25f_y$, and a strength reduction factor, ϕ , of 1.0, in.-lb	S_{gx}, S_{gy}	section moduli of gross section about x and y axes, in. ³
$M_{pr,CS}$	value of M_{pr} at the critical section for flexure and axial load, in.-lb	S_{DS}	design, 5-percent-damped, spectral response acceleration parameter at short periods
M_u	factored moment at section, in.-lb	S_{D1}	design, 5-percent-damped, spectral response acceleration parameter at 1-second period
M_{ux}, M_{uy}	values of M_u about x and y axes, in.-lb	T	fundamental period of the building, seconds
$M_{u,CS}$	value of M_u at the critical section for flexure and axial force, in.-lb	T_a	approximate fundamental period of the building, seconds
N	number of stories from base to roof	T_s	period at intersection of constant acceleration and constant velocity regions of design response spectrum defined in ASCE 7
		T_{s1}	tensile force in distributed vertical reinforcement in wall web, lb

T_{s1}	tensile force in boundary element vertical reinforcement, lb	ε_t	net tensile strain in extreme layer of longitudinal tension steel at nominal strength
T_u	flexural tension force, lb	λ	modification factor reflecting the reduced mechanical properties of lightweight concrete, all relative to normalweight concrete of the same compressive strength
$T_{u,net}$	factored transient net tension forces on section, lb	μ	coefficient of friction defined by ACI 318
v_n	nominal unit shear strength of wall, defined as V_n/l_w , lb/in.	ρ	a redundancy factor based on the extent of structural redundancy present in a building
V	seismic base shear calculated according to the equivalent lateral force procedure of ASCE 7	ρ_{be}	ratio of area of boundary element longitudinal reinforcement to gross area boundary element
V_c	nominal shear strength provided by concrete, lb	ρ_l	ratio of area of distributed longitudinal reinforcement to gross concrete area perpendicular to that reinforcement
V_s	nominal shear strength provided by shear reinforcement, lb	ρ_t	ratio of area of distributed transverse reinforcement to gross concrete area perpendicular to that reinforcement
V_e	design shear force for load combinations including earthquake effects, lb	σ	normal stress used to determine required boundary elements by Method II, psi
V_n	nominal shear strength, lb	ϕ	strength reduction factor
V_u	factored shear force at section, lb	ϕ_o	flexural overstrength factor
V'_u	factored shear force at section after application of dynamic amplification and flexural overstrength factors, lb	ϕ_u	ultimate curvature, in. ⁻¹
$V_{u,CS}$	value of V_u at critical section, lb	ψ_t	factor used to modify development and lap splice length based on reinforcement location
w_u	factored load per unit length of beam	ω	dynamic amplification factor
W	effective seismic weight of building, lb	Ω_o	amplification factor to account for overstrength of the seismic force-resisting system defined in ASCE 7
x_p	horizontal distance between centroids of flexural compressive force and wall axial force, P_u , measured in plane of wall, in.		
α	angle defining the orientation of reinforcement relative to longitudinal axis		
α_c	coefficient defining the relative contribution of concrete to nominal wall shear strength		
β_l	factor relating depth of equivalent rectangular compressive stress block to neutral axis depth defined by ACI 318		
δ_u	design displacement, in.		
ε_{cu}	nominal compressive strain capacity of plain concrete		
ε_y	strain at f_y for reinforcing steel		

Abbreviations

ACI	American Concrete Institute
ASCE	American Society of Civil Engineers
ATC	Applied Technology Council
IBC	International Building Code
SEAOC	Structural Engineers Association of California
SEI	Structural Engineering Institute

10. Credits

Cover photo	Image courtesy of John Wallace, University of California, Los Angeles
Figure 2-4	Image courtesy of National Information Service for Earthquake Engineering - Pacific Earthquake Engineering Research Center
Figure 3-3	Image courtesy of Ken Elwood, University of British Columbia
Figure 3-4	Image courtesy of W. Gene Corley
Figure 5-11, 7-1, 7-2, 7-3	Images courtesy of Magnusson Klemencic Associates
Figure 5-14	Image courtesy of the American Concrete Institute “reprinted with permission from the American Concrete Institute”
All other images courtesy of Jack Moehle, University of California, Berkeley	